

HGX44e/665-4 S

Engine: 380-420V Y/YY -3- 50Hz PW

Refrigerant: R134a

Subject:

Performance data

Application: Refrigeration & AC

Refrigerant	R134a	Compressor refrigeration capacity	20.10 kW
Reference temperature	Dew point	Evaporator refrigeration capacity	20.10 kW
Power supply	50 Hz, 400 V	Power consumption	7.91 kW
Supply frequency	50 Hz	Current draw (400 V)	16.40 A
Evaporating temperature	-5.0 °C	Coefficient of performance (COP/EER)	2.54
<i>Evaporating pressure (abs.)</i>	<i>2.43 bar</i>	Condensing capacity	28.00 kW
Condensing temperature	50.0 °C	Mass flow	0.138 kg/s
<i>Condensing pressure (abs.)</i>	<i>13.17 bar</i>	Discharge end temperature	94.2 °C ¹⁾
Suction gas temperature	20 °C		
Subcooling (outside cond.)	0 K		
Usable superheat	100%		

Preliminary capacity data.

- 1) The stated value of the discharge end temperature is a mere calculated value. Additional cooling and heat dissipation are not considered. Deviations (particularly in deep freezing applications) from the real measured discharge temperature during operation are possible.

Subject to change without notice

To:

From:

21.02.2024
Page 1 of 11

VAP 11.13.3

HGX44e/665-4 S



Engine: 380-420V Y/YY -3- 50Hz PW

Refrigerant: R134a

Subject:

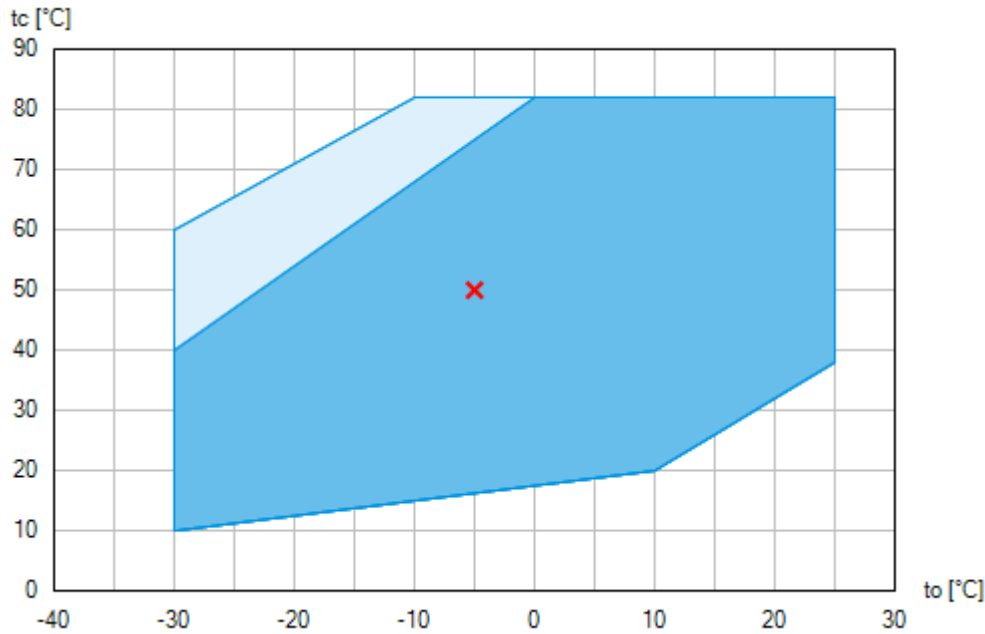
Operating limits



-  Unlimited application range
-  Supplementary cooling or reduced suction gas temperature ($\Delta t_{oh} < 20K$)

Compressor operation is possible within the limits shown on the diagrams of application. Please note the coloured areas. Compressor application limits should not be chosen for design purposes or continuous operation. Axis values refer to dew point (saturated vapour line).

Subject to change without notice

To:

From:

21.02.2024
Page 2 of 11

VAP 11.13.3

HGX44e/665-4 S

Engine: 380-420V Y/YY -3- 50Hz PW

Refrigerant: R134a

Subject:

Technical data

Number of cylinders / Bore / Stroke	4 / 65 mm / 50 mm
Displacement 50/60 Hz (1450/1740 ¹ /min)	57,70 / 69,20 m ³ /h
Voltage ¹⁾	380-420V Y/YY -3- 50Hz PW
	440-480V Y/YY -3- 60Hz PW
Winding divided into	50% / 50%
Max. working current ²⁾	30.0 A
Max. power consumption ²⁾	18.3 kW
Starting current (rotor blocked) ²⁾	101.0 / 174.0 A
Motor protection	INT69 G
Protection terminal box	IP 66
Weight	171 kg
Frequency range ³⁾	25 - 70 Hz
Max. permissible overpressure (g) (LP/HP) ⁴⁾	19 / 28 bar
Connection suction line SV	42 mm - 1 5/8 "
Connection discharge line DV	28 mm - 1 1/8 "
Lubrication	Oil pump
Oil type R134a, R404A, R407A/C/F, R448A, R449A, R450A, R513A	BOCKlub E55
Oil type R22	BOCKlub A46
Oil charge	2,7 Ltr.
Oil sump heater	230 V - 1 - 50/60 Hz, 160 W
Dimensions Length / Width / Height	695 / 361 / 383 mm
Sound power level L _{WA} ⁵⁾	78 db(A) @ -35/+40 °C
	77 db(A) @ -10/+45 °C
	76 db(A) @ +5/+50 °C
Sound pressure level L _{pA} ⁵⁾	65 db(A) @ -35/+40 °C
	64 db(A) @ -10/+45 °C
	63 db(A) @ +5/+50 °C

Subject to change without notice

To:

From:

21.02.2024
Page 3 of 11

VAP 11.13.3

HGX44e/665-4 S

Engine: 380-420V Y/YY -3- 50Hz PW

Refrigerant: R134a

Subject:

-
- 1) Tolerance ($\pm 10\%$) relates to the mean value of the voltage range. Other voltages and current types on request

All data are based on voltage rms values

PW = part winding, motors for part winding starting
(no start unloaders required)
Designs for Y/D on request
 - 2) - The stated value for the max. power consumption is valid for the adjusted power supply.

- Starting current (rotor blocked):
 - Part winding (PW) motors: Winding 1 / Winding 1+2
 - Delta/Star (Δ/Y) motors: Δ / Y- Take account of the max. operating current / max. power consumption for designing motor contractors, feed lines, fuses and motor protection switches. Motor contractors: Consumption category AC3.
 - 3) The maximum permissible working current of the compressor (I_{max}) must not be exceeded. Take account of the guidelines for use of frequency inverter (see compressor assembly instruction or selection software).
 - 4) LP = Low pressure
HP = High pressure
 - 5) Declared dual-number noise emission values are in accordance with ISO 4871. The corresponding uncertainty to the sound power level is $K_{WA} = 2,5$ dB and to the sound pressure level is $K_{pA} = 2,5$ dB. The values are valid for 50 Hz with the refrigerant R404A at the standard rating points according to EN 12900.
 - A-weighted sound power level L_{WA} (re 1 pW), in decibel. To determine the values, measurement methods of the ISO 3740 standard with accuracy class 2 or higher were used .
 - A-weighted sound pressure level L_{pA} (re 20 μ Pa), in decibel. The values are calculated from the sound power level in accordance with ISO 11203: $L_{pA} = L_{WA} - Q_2$ at a distance of $d = 1$ m to the reference box.

Subject to change without notice

To:

From:

21.02.2024
Page 4 of 11

VAP 11.13.3

HGX44e/665-4 S

Engine: 380-420V Y/YY -3- 50Hz PW

Refrigerant: R134a

Subject:

Performance data table

Application: Refrigeration & AC

Reference temperature: Dew point

Supply frequency: 50 Hz

Voltage: 400 V

Suction gas temperature: 20 °C

Subcooling (outside cond.): 0 K

tc [°C]		to [°C]								
		10.0	5.0	0.0	-5.0	-10.0	-15.0	-20.0	-25.0	-30.0
30.0	Q [W]	50000	41200	33600	27100	21500	16800	12800	9500	6800
	P [kW]	6.66	6.65	6.49	6.20	5.81	5.34	4.82	4.27	3.72
	I [A]	15.10	15.10	15.00	14.70	14.30	13.90	13.40	12.90	12.50
35.0	Q [W]	46900	38700	31500	25300	20000	15600	11800	8660	6070
	P [kW]	7.47	7.33	7.06	6.67	6.18	5.63	5.03	4.41	3.79
	I [A]	16.00	15.80	15.50	15.10	14.70	14.10	13.60	13.10	12.50
40.0	Q [W]	43900	36100	29400	23600	18600	14400	10800	7840	5350
	P [kW]	8.26	8.00	7.61	7.11	6.53	5.89	5.21	4.52	3.84
	I [A]	16.80	16.50	16.10	15.60	15.00	14.40	13.80	13.10	12.60
45.0	Q [W]	40900	33600	27300	21800	17200	13200	9830	7020	4640
	P [kW]	9.02	8.64	8.14	7.53	6.85	6.12	5.36	4.59	3.85
	I [A]	17.70	17.20	16.70	16.00	15.30	14.60	13.90	13.20	12.60
50.0	Q [W]	38000	31100	25200	20100	15700	12000	8870	6210	3920
	P [kW]	9.75	9.24	8.62	7.91	7.13	6.30	5.46	4.62	3.80
	I [A]	18.50	17.90	17.20	16.40	15.60	14.80	14.00	13.20	12.60
55.0	Q [W]	35000	28600	23100	18400	14300	10900	7890	5380	3200
	P [kW]	10.40	9.80	9.06	8.23	7.35	6.43	5.50	4.58	3.70
	I [A]	19.30	18.60	17.70	16.80	15.80	14.90	14.00	13.20	12.50
60.0	Q [W]	32100	26100	21000	16600	12900	9640	6910	4550	2460
	P [kW]	11.00	10.20	9.43	8.49	7.50	6.49	5.47	4.47	3.52
	I [A]	20.10	19.10	18.10	17.10	16.00	15.00	14.00	13.10	12.30
65.0	Q [W]	29100	23600	18900	14900	11400	8440	5910	3690	
	P [kW]	11.50	10.70	9.72	8.67	7.58	6.47	5.36	4.28	
	I [A]	20.80	19.70	18.50	17.30	16.10	14.90	13.90	13.00	
70.0	Q [W]	26200	21100	16800	13100	9910	7220	4880		
	P [kW]	12.00	11.00	9.93	8.77	7.57	6.36	5.16		
	I [A]	21.40	20.10	18.70	17.40	16.10	14.80	13.70		

Preliminary capacity data.



Supplementary cooling or reduced suction gas temperature ($\Delta t_{oh} < 20K$)

to Evaporating temperature
tc Condensing temperature
Q Compressor refrigeration capacity
P Power consumption
I Current draw

Subject to change without notice

To:

From:

21.02.2024
Page 5 of 11

VAP 11.13.3

HGX44e/665-4 S

Engine: 380-420V Y/YY -3- 50Hz PW

Refrigerant: R134a

Subject:

Scope of supply

Semi-hermetic four-cylinder reciprocating compressor with drive motor
Single-section compressor housing with hermetically integrated electric motor

Rear bearing flange prepared for oil differential pressure sensor DELTA-P II

Winding protection with PTC resistor sensors and electronic trigger unit INT69 G
115-230 V AC, 50/60 Hz, IP00

Oil pump

Possibility of connection of oil level controllers ESK, AC+R or CARLY

Possibility of connection of oil level controllers Traxoil ¹⁾

Possibility for connection of oil pressure safety switch MP54

Oil charge:

HG: **BOCK**lub A46

HGX: **BOCK**lub E55

Sight glass

Pressure relief valve

Suction and discharge line valve

Inert gas charge

Accessories

(Digital) capacity regulator DCR14 230 V - 1 - 50/60 Hz, IP65
possible equipment see Capacity regulator 09900-DGbF

Cylinder cover prepared for digital capacity regulator

Oil sump heater 230 V - 1 - 50/60 Hz, 160 W

Oil pressure safety switch MP54 230 V - 1 - 50/60 Hz, IP20 ²⁾

USB converter for INT69 G Diagnose ²⁾

Intermediate flange for discharge line valve on right or left seen from oil pump

Oil differential pressure sensor DELTA-P II 220-240 V - 1 - 50/60 Hz ³⁾

Connection piece suction and discharge valve in welding design

Thermal protection thermostat per cylinder cover

INT69 GTML Diagnose 115-230 V AC, 50/60 Hz, IP00, including oil differential pressure sensor INT250G,
thermal protection thermostat per cylinder covers, (INT69 G not applicable) ²⁾

Oil temperature sensor (Pt1000, for external evaluation) ²⁾

Subject to change without notice

To:

From:

21.02.2024
Page 6 of 11

VAP 11.13.3

HGX44e/665-4 S

Engine: 380-420V Y/YY -3- 50Hz PW

Refrigerant: R134a

Subject:

INT69 G Diagnose 115-230 V AC, 50/60 Hz, IP00 (INT69 G not applicable)

DP-Modbus Gateway 115-230 V AC, 50/60 Hz, IP00 including adapter cable ²⁾

Modbus-LAN Gateway 230 V AC, 50/60 Hz, IP00 ²⁾

Additional fan

230 V AC - 1 - 50 Hz, 97 W, IP44

230 V AC - 1 - 60 Hz, 128 W ²⁾

Step protection

Injection nozzle for liquid injection ²⁾

4 anti-vibration pads enclosed

Special voltage and/or frequency (on request)

-
- 1) Only with additional adapter possible
 - 2) Enclosure
 - 3) Enclosure (screw-in part mounted)

Subject to change without notice

To:

From:

21.02.2024
Page 7 of 11

VAP 11.13.3

HGX44e/665-4 S

Engine: 380-420V Y/YY -3- 50Hz PW

Refrigerant: R134a

Subject:

Dimensions and connections

Subject to change without notice

To:

From:

21.02.2024
Page 8 of 11

VAP 11.13.3

HGX44e/665-4 S

Engine: 380-420V Y/YY -3- 50Hz PW

Refrigerant: R134a

Subject:

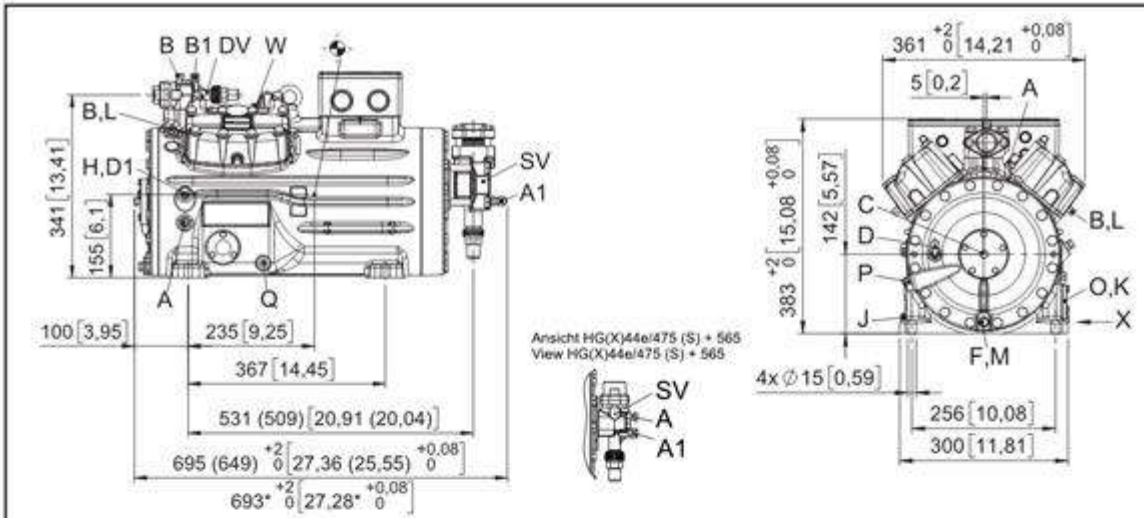

Maße in () für HG(X)44e/475 (S) + 565 (HC + LG)
Dimensions in () for HG(X)44e/475 (S) + 565 (HC + LG)

Maße mit * für HG(X)44e/565 S + 665 (S) + 770 (S) HC + LG
Dimensions with * for HG(X)44e/565 S + 665 (S) + 770 (S) HC + LG

Änderungen vorbehalten
Subject to change without notice

Massenschwerpunkt
Center of gravity

Maße in mm [Zoll]
Dimensions in mm [inch]

Maße Zubehör / Dimensions Accessories

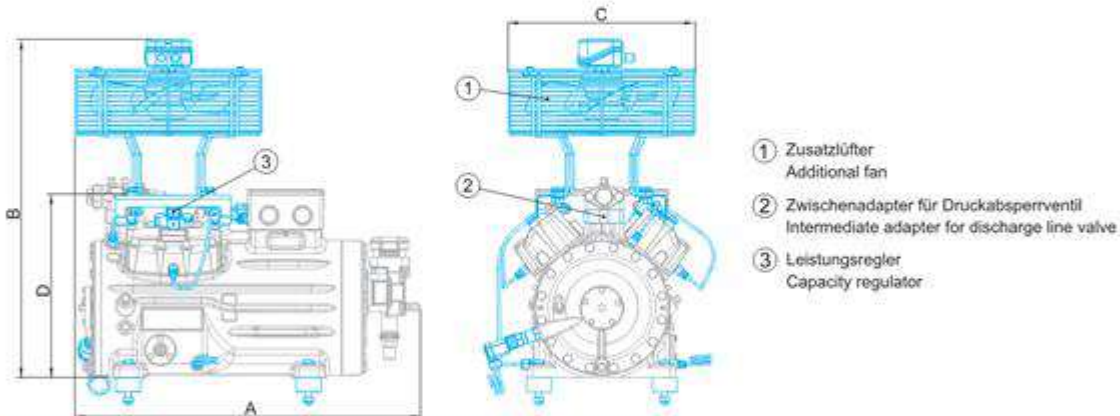

Typ / Type	A mm / inch	B mm / inch	C mm / inch	D mm / inch
HG12P	ca. 460 / 18	ca. 500 / 20	ca. 315 / 12	-
HG22e	ca. 525 / 21	ca. 610 / 24	ca. 380 / 15	-
HG34e	ca. 580 / 23	ca. 640 / 25	ca. 380 / 15	-
HG44e	ca. 710 / 28	ca. 685 / 27	ca. 380 / 15	368 / 14
HG56e	-	ca. 710 / 28	ca. 380 / 15	-
HG66e	ca. 820 / 32	ca. 800 / 31	ca. 380 / 15	-

Ansicht X: Anschlussmöglichkeit für Ölspiegelregulator
View X: Possibility of connection of oil level regulator



- Dreilochanschluss für TRAXOIL (3xM6x10)
Three-hole connection for TRAXOIL (3xM6x10)
- Dreilochanschluss für ESK, AC+R, CARLY (3xM6x10)
Three-hole connection for ESK, AC+R, CARLY (3xM6x10)

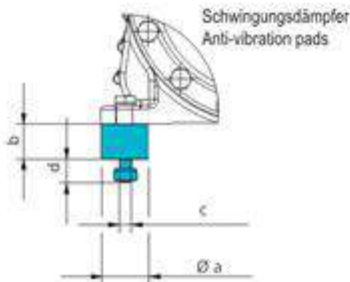

Typ / Type	Øa mm / inch	b mm / inch	c mm / inch	d mm / inch
HG12P	30 / 1.2	30 / 1.2	M8	20 / 0.8
HG22e	40 / 1.6	30 / 1.2	M10	20 / 0.8
HG34e	40 / 1.6	30 / 1.2	M10	20 / 0.8
HG44e	50 / 2.0	30 / 1.2	M12	25 / 1.0
HG56e	50 / 2.0	30 / 1.2	M12	25 / 1.0
HG66e	50 / 2.0	30 / 1.2	M12	25 / 1.0
HG88e	70 / 2.8	45 / 1.8	M12	37 / 1.5

Subject to change without notice

To:

From:

21.02.2024
Page 9 of 11

VAP 11.13.3

HGX44e/665-4 S

Engine: 380-420V Y/YY -3- 50Hz PW

Refrigerant: R134a

Subject:

SV	Suction line valve, tube \varnothing ¹⁾	42 mm - 1 5/8 "
DV	Discharge line valve, tube \varnothing ¹⁾	28 mm - 1 1/8 "
A	Connection suction side, not lockable	1/8 " NPTF
A1	Connection suction side, lockable	7/16 " UNF
B	Connection discharge side, not lockable	1/8 " NPTF
B1	Connection discharge side, lockable	7/16 " UNF
C	Connection oil pressure safety switch OIL	1/8 " NPTF
D	Connection oil pressure safety switch LP	7/16 " UNF
D1	Connection oil return from oil separator	1/4 " NPTF
F	Oil drain	M 12 x 1.5
H	Oil charge plug	1/4 " NPTF
J	Connection oil sump heater	3/8 " NPTF
K	Sight glass	3 x M 6
L	Connection thermal protection thermostat	1/8 " NPTF
M	Oil strainer	M 12 x 1.5
O	Connection oil level regulator	3 x M 6
P	Connection oil differential pressure sensor	M 20 x 1.5
Q	Connection oil temperature sensor	1/8" NPTF
W	Connection for refrigerant injection	1/8" NPTF

1) Brazing connection

Subject to change without notice

To:

From:

21.02.2024
Page 10 of 11

VAP 11.13.3

HGX44e/665-4 S

Engine: 380-420V Y/YY -3- 50Hz PW

Refrigerant: R134a

Subject:

BOCK colour the world
of tomorrow

Product photo



Subject to change without notice

To:

From:

21.02.2024
Page 11 of 11

VAP 11.13.3