



— MODELS —

CRL & 55F Pressure Relief Valves



CRL



55F

- Direct Acting - Precise Pressure Control
- Positive Dependable Opening
- Drip Tight Closure
- No Packing Glands or Stuffing Boxes
- Sensitive to Small Pressure Variations

The Cla-Val Model CRL and 55F Pressure Relief Valves are direct-acting, spring loaded, diaphragm type relief valves. Often used as pilot controls for Cla-Val Hytrol valves, they can also be used as self-contained pressure relief valves. These valves may be installed in any position and open and close within very close pressure limits.

The Model CRL and 55F are normally held closed by the force of the compression spring above the diaphragm. Control pressure is applied under the diaphragm. When the controlling pressure exceeds the spring setting, the disc is lifted off its seat, permitting flow through the control. When control pressure drops below the spring setting, the spring forces the control back to its normally closed position. The controlling pressure is applied to the chamber beneath the diaphragm through an external tube on the Model 55F and a sensing port on the CRL.

Pressure adjustment is simply a matter of turning the adjusting screw to vary the spring pressure on the diaphragm. The CRL & 55F are available in four pressure ranges: 0 to 75 psi, 20 to 105 psi, 20 to 200 psi, and 100 to 300 psi. To prevent tampering, the adjustment cap can be wire sealed by using the lock wire holes provided in the cap and cover.

Note: Also Available in Seawater Service Material

Dimensions (In Inches) 55F Model

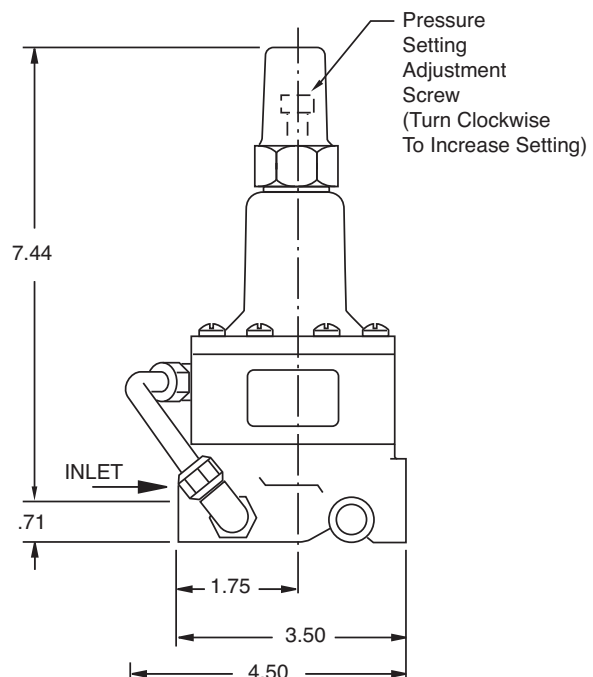
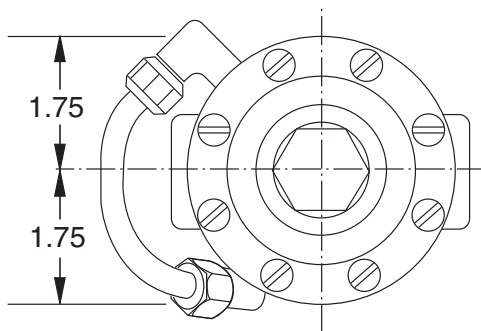

Specifications

Size 1/2" & 3/4" Threaded
Temperature Range Water, Air: to 180°F Max.
Materials

Body & Cover: Low Lead Bronze
 Cast Aluminum 356-T6
 Stainless Steel ASTM A743-CF-16Fa
Trim: Brass & Stainless Steel 303
Rubber: Buna-N® Synthetic Rubber

CRL & 55F Range PSI	Approximate Increase For Each Clockwise Turn Of Adjusting Screw
0 to 75	8.5 psi
20 to 105	12.0 psi
20 to 200	28.0 psi
100 to 300	18.0 psi

Pressure Ratings Cast Bronze 400 psi Max.
 Cast Aluminum 275 psi Max.
 Stainless steel 400 psi Max.

Other Materials Available on special order

Adjustment Ranges 0 to 75 psi
 20 to 105 psi
 20 to 200 psi
 100 to 300 psi
 250 to 600 psi (see E-CRL-18 sheet)

Pressure Drop Chart (Full Open Valve)

Valve Size	C _v Factor	Flow of Water - gpm				
		5	10	15	20	30
1/2"	6	0.7	2.7	6	11	----
3/4"	8.5	0.3	1.4	3.1	5.5	12.2

CRL Basic Valve Dimensions (In Inches)

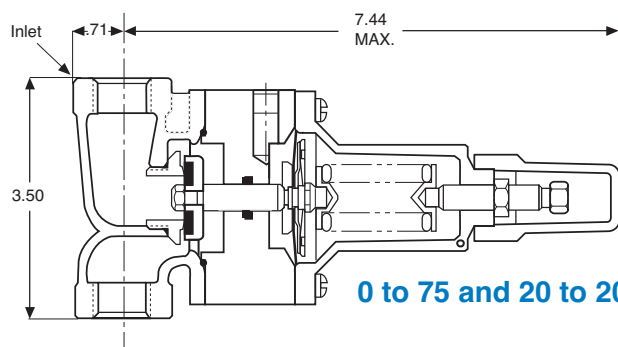

0 to 75 and 20 to 200 psi Design

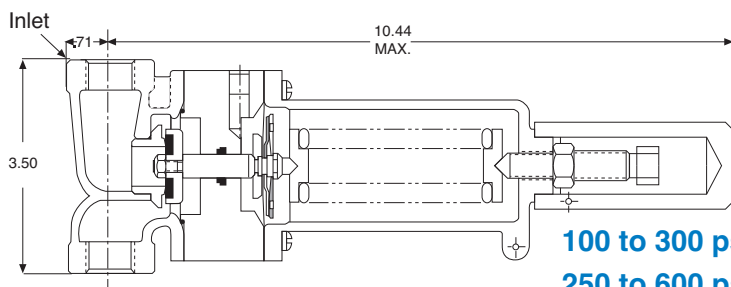
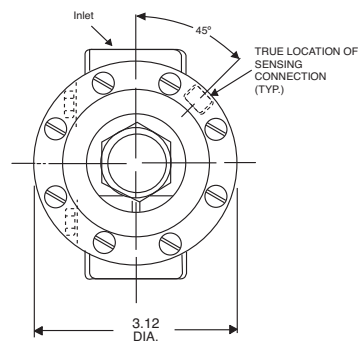

**100 to 300 psi Design
 250 to 600 psi Design**

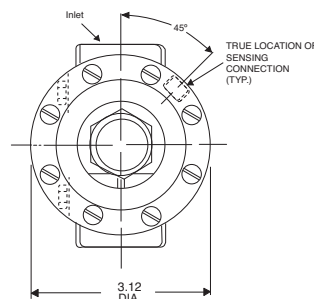

OPTIONAL X140 SECURITY CAP



X140-1
 Locking
 Security
 Cap

- Controlled Security for Pilot Control Adjustment
- Long Life Stainless Steel Construction
- Tamper-Resistant Design
- X140-1 Key and Six Pin Cylinder Lock Supplied

When Ordering, Please Specify

1. Catalog No. CRL & 55F 2. Valve Size 3. Adjustment Range Desired 4. Optional Materials 5. Optional Security Cap



E-CRL/55F (R-03/2021)

CLA-VAL

1701 Placentia Avenue • Costa Mesa, CA 92627