

D191

D191

Threaded DZR Ball Valve

PN25

Features & Benefits

- Designed to be light, compact and easy to install and operate
- Features improved leak resistance and reduced risk of damage from over tightening
- Tested by BSI and complies with essential requirements of BS EN 331:1998
- Also suitable for natural gas applications

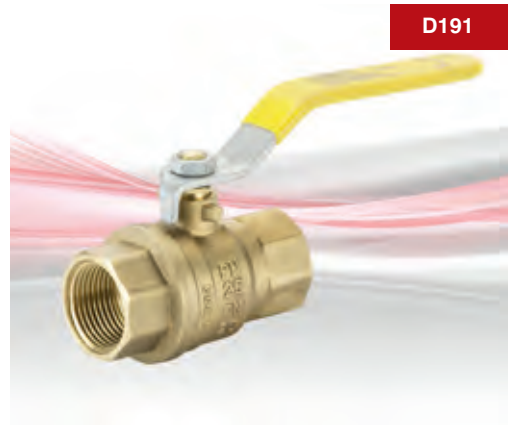

Materials

PART	MATERIAL
Hex-Nut	Dacromet Plated Steel
Handle Sleeve	PVC Yellow
Handle	Dacromet Plated Steel
Packing Nut	Brass CW617N
Packing Gland	PTFE (WRAS Approved)
Body	DZR Brass CW602N
Ball	DZR Brass Chrome Plated
Seats	PTFE (WRAS Approved)
O-Ring	NBR with BS EN 549 Approval
Bonnet	DZR Brass CW602N
Stem	DZR Brass CW602N

Dimensional Drawing

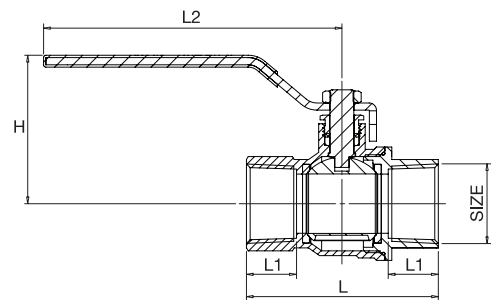

All dimensions are nominal.

Dimensions & Weights

SIZE (inch)	WEIGHT (kg)	L (mm)	L1 (mm)	L2 (mm)	H (mm)
1/4	0.152	46	12	89	41
3/8	0.136	46	12	89	41
1/2	0.205	59	15.5	98.5	48
3/4	0.302	67	17	98.5	51
1	0.511	80.5	21	125	63
1 1/4	0.890	94	23	140	78
1 1/2	1.292	102	23	140	83.5
2	2.238	124	26.5	165	97.5

Pressure/Temperature Ratings

Non Gas application

TEMPERATURE (°C)	-10 to 100	110
PRESSURE (BAR)	25	23.5

Intermediate pressure ratings shall be determined by interpolation.

Natural Gas application

TEMPERATURE (°C)	-20 to 60
PRESSURE (BAR)	5

Intermediate pressure ratings shall be determined by interpolation. Gas approved to BS EN 331:1998

PRESSURE RATING: PN25

TEMPERATURE OPERATING RANGE: Non Gas -10 to 110°C, Gas -20 to 60°C

UK END CONNECTION: Taper threaded to BS EN 10226-2 (ISO 7-1) formerly BS 21

US END CONNECTION: ANSI B1.20.1:1983 (please add suffix AT to denote American Thread)

OPERATOR: Lever

SPECIFICATION: Quarter Turn, PTFE Seats and Stem Seal.

Tested by BSI and complies with the essential requirements of BS EN 331:1998.