

914

Ductile Iron Soft Sealed Flanged Gate Valve



Via Circonvallazione, 10
13018 Valduggia (VC), Italy
Tel: +39 0163 47891
Fax: +39 0163 47895
www.vironline.com



Ductile iron soft sealed gate valve
Flanged PN16 according to EN1092-2 (ex DIN2533)
Flat body, lengths according EN558-1 series 14 (ex DIN3202 F4)
Epoxy coating (min. 250µm)
Non rising stem
TR CU 010 compliant

PN16
Free of CE marking for DN≤300 (cat. according to Art. 4.3 Dir. 2014/68/EU)

Working conditions

- Suitable for: water, 0°C to +100°C
- Not suitable for: gases group 1 & 2, liquids group 1 (Dir. 2014/68/EU)



PARTLIST

N.	Part	Material	Norm
1	Body	Ductile iron	EN-GJS 450-10
2	Wedge	Ductile iron + EPDM	EN-GJS 450-10
3	Wedge nut	Brass	-
4	Bonnet	Ductile iron	EN-GJS 450-10
5	Bolt	Carbon steel	-
6	Stem	Stainless steel	2Cr13
7	Gasket	EPDM	-
8	Clamp	Brass	-
9	Stem O-ring	EPDM	-
10	Dust O-ring	EPDM	-
11	Nut	Brass	-
12	Handwheel	Ductile iron	EN-GJS 450-10
13	Nut and washer	Stainless steel	1Cr13

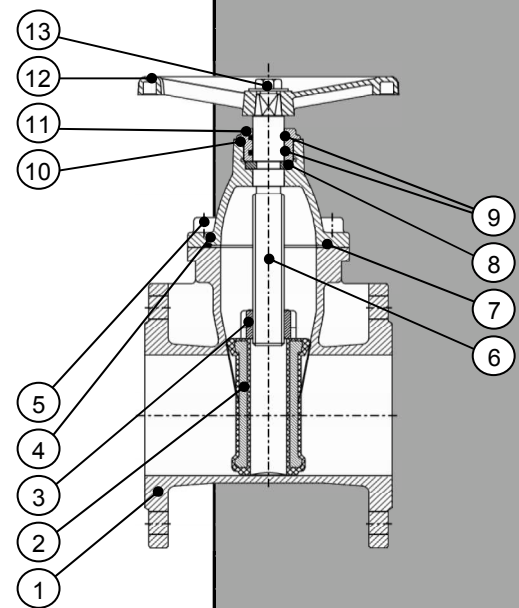

DIMENSIONS

DN	ØF [mm]	ØE [mm]	S [mm]	NxØD [mm]	H [mm]	L [mm]	ØV [mm]	Weight [kg]
040	150	110	15	4x19	184	140	160	9
050	165	125	16	4x19	195	150	160	12
065	185	145	16	4x19	222	170	200	14
080	200	160	16	8x19	251	180	200	18
100	220	180	16	8x19	282	190	200	23
125	250	210	16	8x19	340	200	250	30
150	285	240	16	8x23	379	210	250	39
200	340	295	17	12x23	461	230	320	60
250	405	355	19	12x28	559	250	370	95
300	460	410	21	12x28	639	270	370	130
350	520	470	23	16x28	762	290	450	195
400	580	525	24	16x31	836	310	450	252

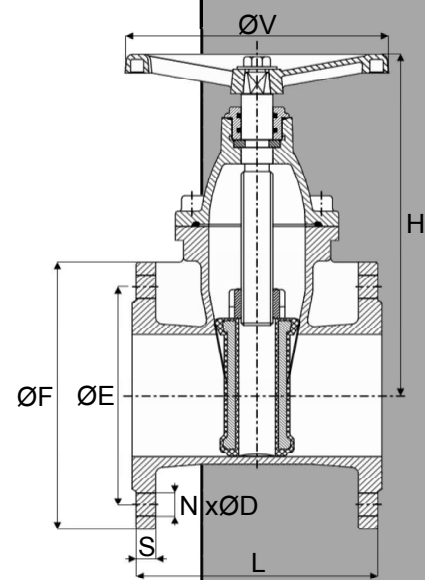

180925