



Honeywell |

Pressure Reducing Valves

D06F

Pressure Reducing Valve

With Balanced Seat and Set Point Scale

APPLICATION

According EN 806-2 pressure reducing valves of this type protect household water installations against excessive pressure from the supply. They can also be used for industrial or commercial applications within the range of their specification.

By installing a pressure reducing valve, pressurisation damage is avoided and water consumption is reduced.

The set pressure is also maintained constant, even when there is wide inlet pressure fluctuation.

Reduction of the operating pressure and maintaining it at a constant level minimizes flow noise in the installation.

APPROVALS

- DVGW



- WRAS (up to 23°C)

SPECIAL FEATURES

- Inlet pressure balancing – no influence on outlet pressure by fluctuating inlet pressure
- Up to size 1 1/4" approved by LGA for low noise, Group 1 without limitations
- The valve insert is of high quality synthetic material and can be fully exchanged
- The outlet pressure is set by turning the adjustment knob
- The set pressure is directly indicated on the set point scale
- The adjustment spring is not in contact with the drinking water
- Integral fine filter
- Also available without fittings
- Conforms to BSEN 1567
- All materials are UBA conform
- All materials are ACS approved

TECHNICAL DATA

Media	
Medium:	Drinking water
Connections/Sizes	
Connection sizes:	1/2" - 2"
Nominal sizes:	DN15 - DN50
Pressure values	
Max. inlet pressure with clear filter bowl:	16 bar
Max. inlet pressure with brass filter bowl:	25 bar
Outlet pressure:	1.5 - 6 bar
Preset outlet pressure:	3 bar
Min. pressure drop:	1 bar
Operating temperatures	
Max. operating temperature medium with clear filter bowl:	40 °C
Max. operating temperature medium with brass filter bowl:	70 °C *

* max. operating pressure 10 bar

Note: Use the SM06T brass filter bowl, if the valve can be exposed to UV radiation or solvent vapors.

CONSTRUCTION

Overview

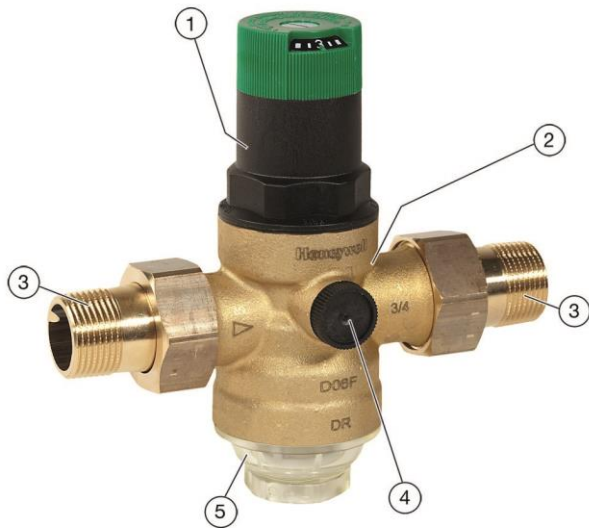

Components

Materials

1	Spring bonnet with adjustment knob and setting scale	High-quality synthetic material
2	Housing with pressure gauge connections on both sides	Dezincification-resistant brass
3	Threaded male connections (options A & B)	Brass
4	Pressure gauge connection	-
5	Filter bowl	Clear synthetic or brass

Not depicted components

Adjustment spring	Spring steel
Valve insert complete with diaphragm and valve seat	High-quality synthetic material, EPDM diaphragm
Fine filter with 0.16 mm mesh	Stainless steel
Pressure gauge (see accessories)	High-quality synthetic material

Seals	EPDM
Max. ambient relative humidity:	85 % *

*non condensing

METHOD OF OPERATION

Spring loaded pressure reducing valves operate by means of a force equalising system. The force of a diaphragm operates against the force of an adjustment spring. If the outlet pressure and therefore diaphragm force fall because water is drawn, the then greater force of the spring causes the valve to open. The outlet pressure then increases until the forces between the diaphragm and the spring are equal again.

The inlet pressure has no influence in either opening or closing of the valve. Because of this, inlet pressure fluctuation does not influence the outlet pressure, thus providing inlet pressure balancing.

TRANSPORTATION AND STORAGE

Keep parts in their original packaging and unpack them shortly before use.

The following parameters apply during transportation and storage:

Parameter	Value
Environment:	clean, dry and dust free
Min. ambient temperature:	5 °C
Max. ambient temperature:	55 °C
Min. ambient relative humidity:	25 % *

2 Product Specification Sheet • EN0H-1002GE23 R0117 • Subject to change

INSTALLATION GUIDELINES

Setup requirements

- Install in horizontal pipework with filter bowl downwards
- Install shut-off valves
- The device downstream should be protected by means of a safety valve (installed downstream of the pressure reducing valve). In these cases the delivery pressure of the pressure reducing valve shall be set to at least 20% below the response pressure of the pressure relief-valve according to EN 806-2
- The installation location should be protected against frost and be easily accessible
 - Pressure gauge can be read off easily
 - With clear filter bowl, degree of contamination can be easily seen
 - Simplified maintenance and cleaning
- Install downstream of the filter or strainer
- Provide a straight section of pipework of at least five times the nominal valve size after the pressure reducing valve (in accordance with EN 806-2)
- Requires regular maintenance in accordance with EN 806-5

D06F - Pressure Reducing Valve

Installation Example

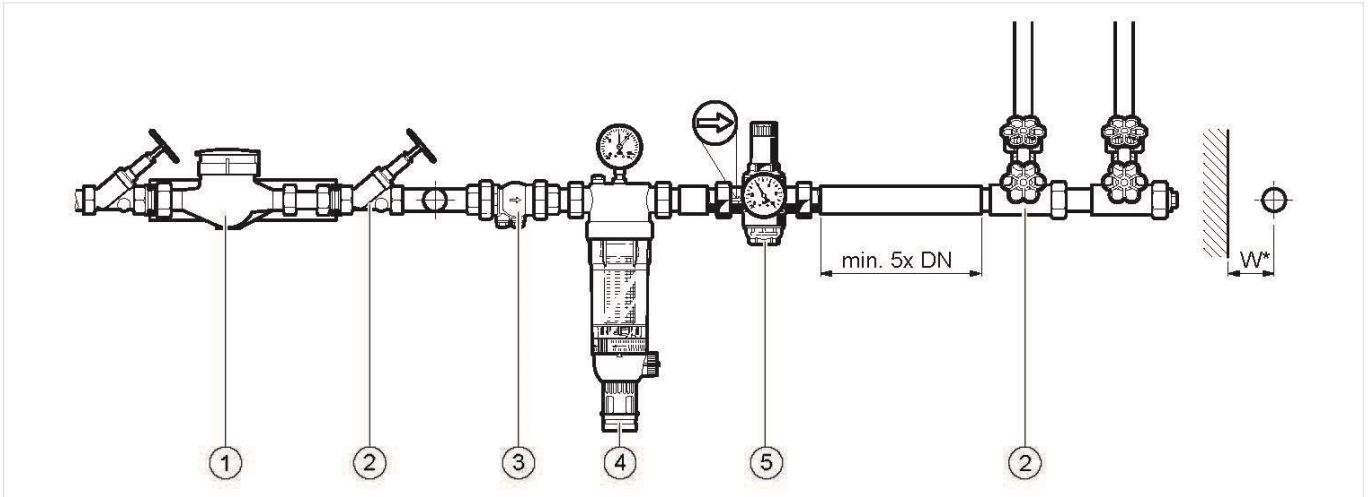

Fig. 1 Standard installation example for the pressure reducing valve

- 1 Water meter
- 2 Shut-off valve
- 3 Check valve
- 4 Filtering unit
- 5 Pressure reducing valve

Connection sizes:

DN:	15	20	25	32	40	50
inch:	1/2"	3/4"	1"	1 1/4"	1 1/2"	2"
Distance in mm (W*):	55	60	60	60	70	70

* Required installation distances between the centerline of the pipework and the surrounding in dependency of the connection size.

TECHNICAL CHARACTERISTICS

kvs-Values

Connection sizes:	15	20	25	32	40	50
k _{vs} -value (m ³ /h):	2.4	3.1	5.8	5.9	12.6	12.0
IfBt designation:	P-IX 1582/I	P-IX 1582/I	P-IX 1582/I	P-IX 1582/I	- *	- *
DVGW registration number:	DW-6330 AT 2314					

* Compulsory testing in sizes R 1/2" to R 1 1/4"

Pressure drop characteristics

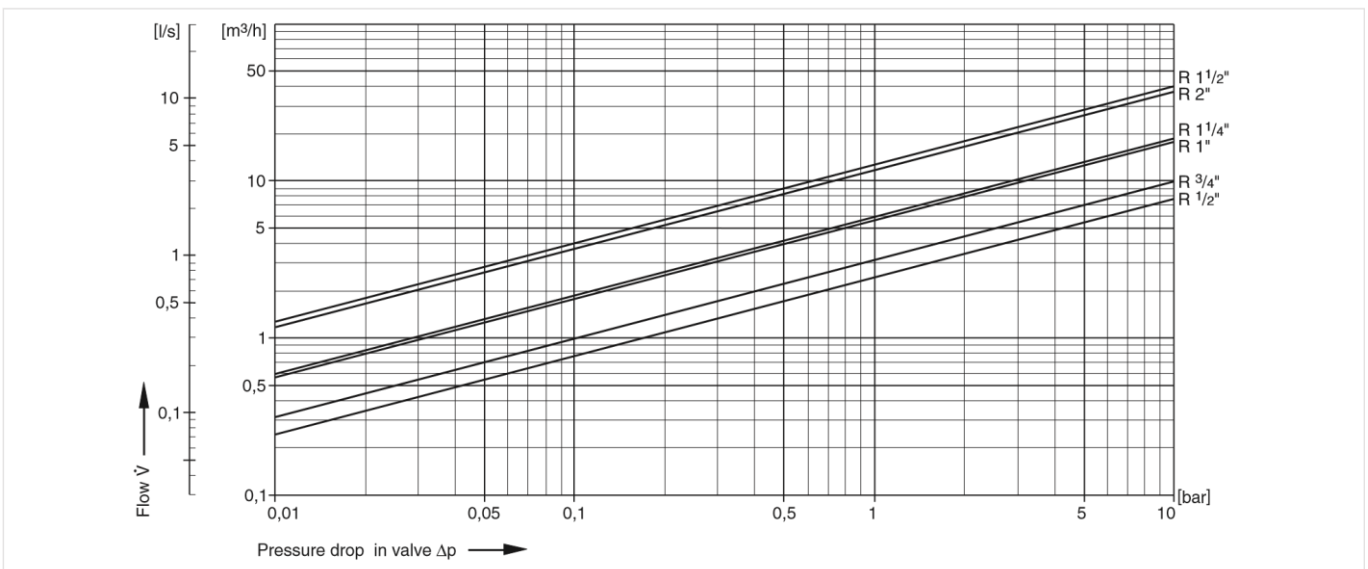
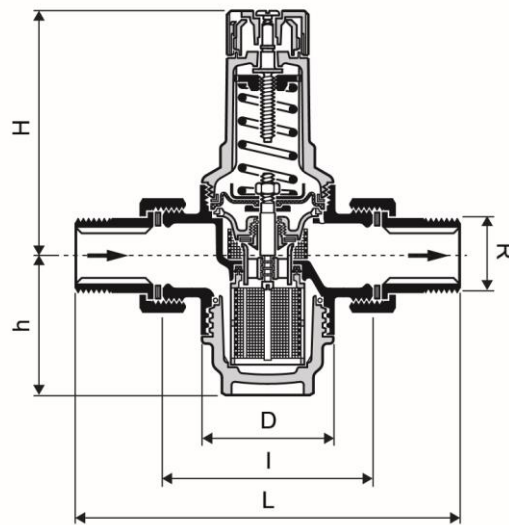

Fig. 2 Pressure drop within the valve in dependency of the flow rate and the used connection size

DIMENSIONS

Overview



Parameter	Values						
Connection sizes:	R	1/2"	3/4"	1"	1 1/4"	1 1/2"	2"
Nominal size diameter:	DN	15	20	25	32	40	50
Weight:	kg	0.8	1.0	1.4	2.0	3.3	4.5
Dimensions:	L	140	160	180	200	225	255
	I	80	90	100	105	130	140
	H	89	89	111	111	173	173
	h	58	58	64	64	126	126
	D	54	54	61	61	82	82

Note: All dimensions in mm unless stated otherwise.

ORDERING INFORMATION

The following tables contain all the information you need to make an order of an item of your choice. When ordering, please always state the type, the ordering or the part number.

Options

The valve is available in the following sizes: 1/2", 3/4", 1", 1 1/4", 1 1/2" and 2".





- standard
- not available

		D06F-...A	D06F-...B	D06F-...E
Max. operating temperature medium:	40 °C	•	–	•
	70 °C	–	•	–
Filter bowl:	clear	•	–	•
	brass	–	•	–
Connection type:	external threaded connection set on in- and outlet	•	•	–
	external thread on in- and outlet	–	–	•

Note: ... = space holder for connection size

Note: Ordering number example for 1 1/4" and type A valve: D06F-11/4A

Accessories

	Description	Dimension	Part No.
	M07M Pressure gauge		
	Housing diameter 63 mm, rear connection thread G 1/4"		
	Range: 0 - 4 bar		M07M-A4
	Range: 0 - 10 bar		M07M-A10
	Range: 0 - 16 bar		M07M-A16
	Range: 0 - 25 bar		M07M-A25
	ZR06K Double ring wrench		
	For removal of spring bonnet and filter bowl		ZR06K
	VST06A Connection set		
	Threaded connections		
		1/2"	VST06-1/2A
		3/4"	VST06-3/4A
		1"	VST06-1A
		1 1/4"	VST06-11/4A
		1 1/2"	VST06-11/2A
	2"	VST06-2A	
	VST06B Connection set		
	Solder connections		
		1/2"	VST06-1/2B
		3/4"	VST06-3/4B
		1"	VST06-1B
		1 1/4"	VST06-11/4B
		1 1/2"	VST06-11/2B
		2"	VST06-2B

Product Specification Sheet • EN0H-1002GE23 R0117 • Subject to change

Spare Parts

Pressure Reducing Valve D06F, from 1997 onwards

Overview	Description	Dimension	Part No.
1 Spring bonnet complete		1/2" - 1"	0901515
		1" + 1 1/4"	0901516
		1 1/2" + 2"	0901518
2 Valve insert complete (without filter)		1/2" + 3/4"	D06FA-1/2
		1" + 1/4"	D06FA-1B
		1 1/2" + 2"	D06FA-11/2
3 Union seal washer (10 p cs.)		1/2"	0901443

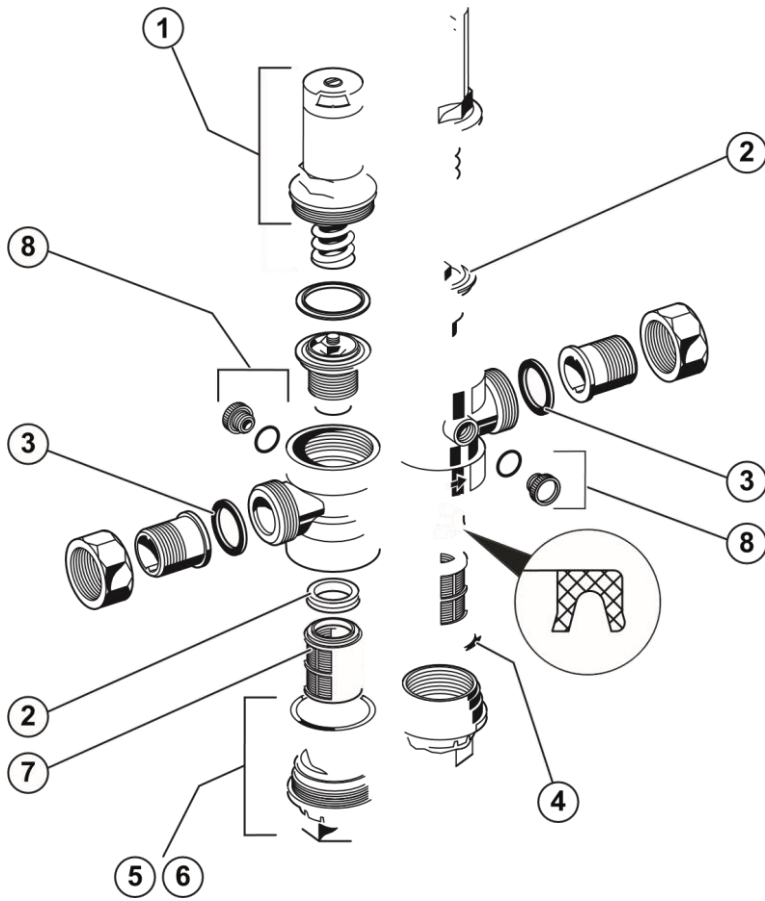

	3/4"	0901444
	1"	0901445
	1 1/4"	0901446
	1 1/2"	0901447
	2"	0901448
4	O-ring set (10 pcs.)	
	1/2" + 3/4"	0901246
	1" + 1 1/4"	0901499
	1 1/2" + 2"	0901248
5	Clear filter bowl with Oring	
	1/2" + 3/4"	SK06T-1/2
	1" + 1 1/4"	SK06T-1B
	1 1/2" + 2"	SK06T-11/2
6	Brass filter bowl with O -ring	
	1/2" + 3/4"	SM06T-1/2
	1" + 1 1/4"	SM06T-1B
	1 1/2" + 2"	SM06T-11/2
7	Replacement filter inse rt	
	1/2" + 3/4"	ES06F-1/2A
	1" + 1 1/4"	ES06F-1B
	1 1/2" + 2"	ES06F-11/2A
8	Blanking plug with O-ri ng R¹/₄" (5 pcs .)	
	1/2" - 2"	S06K-1/4

Manufactured for and on behalf of the

Environmental and Combustion Controls

Division of Honeywell Technologies Sàrl, Z.A. La Pièce 16,
1180 Rolle, Switzerland by its Authorised Representative
Honeywell GmbH

EN0H-1002GE23 R0117

Subject to change

© 2017 Honeywell GmbH

Honeywell



For More Information, Please Contact

Diera - 04 3361377
Al Quoz - 04 3387577

Email
info@anbisolutions.com
websales@anbisolutions.com
www.anbisolutions.com