

924

Cast Iron Metal Sealed Flanged Gate Valve



Via Circonvallazione, 10
13018 Valduggia (VC), Italy
Tel: +39 0163 47891
Fax: +39 0163 47895
www.vironline.com



Cast iron metal sealed flanged gate valve
Flanged PN16 according to EN1092-2 (ex DIN2533)
Lengths according to EN558-1 series 14 (ex DIN3202 F4)
Adjustable packing, non rising stem
TR CU 010 compliant

PN16
Free of CE marking (cat. according to Art. 4.3 Dir. 2014/68/EU)

Working conditions

- Suitable for: water, 0°C to +110°C
- Not suitable for: gases group 1 & 2, liquids group 1 (Dir. 2014/68/EU)



EAC

PARTLIST

N.	Part	Material	Norm
1	Body	Cast iron ¹	GG25
2	Seat	Brass	-
3	Wedge seal	Brass	-
4	Wedge	Cast iron	-
5	Stem nut	Brass	-
6	Stem	Stainless steel	-
7	Bolt and nut	Zinc plated steel	-
8	Gasket	Graphite	-
9	Bonnet	Cast iron ²	-
10	Packing	Graphite	-
11	Gland	Ductile iron	-
12	Gland bolt and nut	Zinc plated steel	-
13	Handwheel	Ductile iron	-
14	Nut	Zinc plated steel	-

¹Ductile iron GGG40 for DN≥200

²With ductile iron packing box

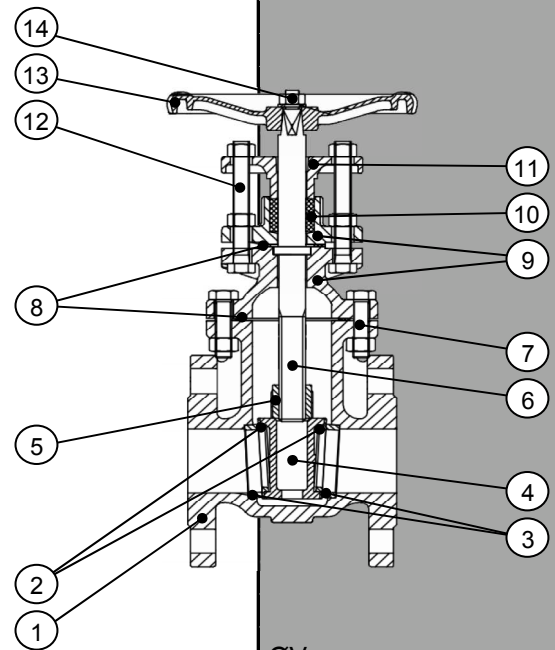

DIMENSIONS

DN	ØF [mm]	ØE [mm]	S [mm]	NxØD [mm]	H [mm]	L [mm]	ØV [mm]	Weight [kg]
050	165	125	18	4x19	289	150	180	15,0
065	185	145	18	4x19	306	170	200	18,1
080	200	160	20	8x19	332	180	200	22,4
100	220	180	22	8x19	380	190	240	31,4
125	250	210	24	8x19	420	200	260	40,5
150	285	240	24	8x23	485	210	280	56,2
200	340	295	18	12x23	490	230	320	81,5
250	405	355	20	12x28	707	250	360	130,3
300	460	410	26	12x28	807	270	400	187,2

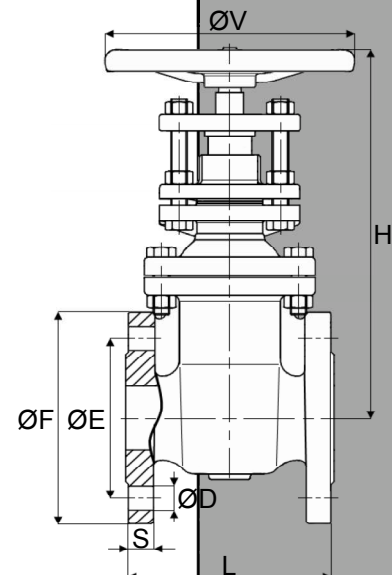

190409