

# 776

## Cast Iron Dual Plate Check Valve



Via Circonvallazione, 10  
 13018 Valduggia (VC), Italy  
 Tel: +39 0163 47891  
 Fax: +39 0163 47895  
 www.vironline.com



Cast iron dual plate check valve  
 Wafer type suitable for EN1092 PN16 flanges  
 Suitable also for flanges PN10 up to DN≤250  
 Design according to EN12334  
 Testing according to EN12266-1  
 Lengths according to EN558-1 series 16  
 To be installed horizontally or vertically (with upward flow)  
 Provided with eyebolt for DN≥125  
 Minimum opening pressure 0,04bar  
 TR CU 010 compliant

PN16

Free of CE marking for DN≤300 (cat. according to Art. 4.3 Dir. 2014/68/EU)

Working conditions

- Suitable for: water, 0°C to +110°C
- Not suitable for: gases group 1 & 2, liquids group 1 (Dir. 2014/68/EU)



### PARTLIST

N.	Part	Material	Norm
1	Body	Cast iron	GG25
2	Seat	EPDM	-
3	Disc	Stainless Steel	SS316
4	Stem	Stainless Steel	SS316
5	Spring	Stainless Steel	SS316
6	Washer	PTFE	-
7	Plug	Stainless Steel <sup>1</sup>	SS316

<sup>1</sup>With EPDM gasket

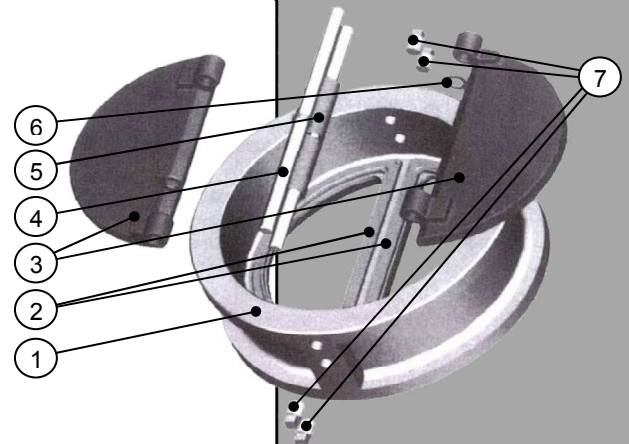

### DIMENSIONS

DN	ØA [mm]	ØB [mm]	ØD [mm]	L [mm]	K <sub>v</sub> [m <sup>3</sup> /h]	Weight [kg]
050	109	71	43	43	40	1,5
065	129	80	60	46	59	2,0
080	144	98	70	64	104	2,8
100	164	117	85	64	208	4,1
125	194	145	115	70	376	6,4
150	220	172	134	76	635	8,5
200	275	221	176	89	1050	13,5
250	330	276	218	114	1697	22,0
300	386	326	255	114	3265	30,0
350	446	361	293	127	4108	48,0
400	498	412	350	140	6205	65,0
450	558	468	383	152	7900	78,0
500	620	515	432	152	12728	110,0
600	737	624	538	178	21930	157,0

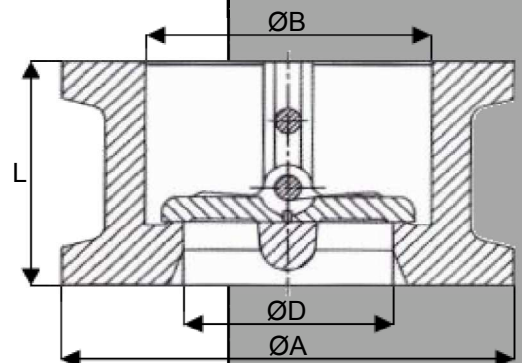

190507