

HERZ - Strainer with internal, external thread or flanged model

Datasheet for 2662 / 4111, Issue 0525

With internal thread

Dimensions

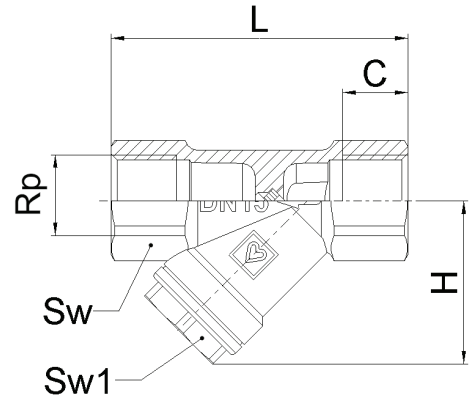

Order number	DN	PN [bar]	Rp [in]	C [mm]	L [mm]	H [mm]	Sw [mm]	Sw1 [mm]	Kvs [m ³ /h]	Mass [kg]
1 2662 11	15	25	1/2"	15	68	37	25	22	2,55	0,176
1 2662 12	20	25	3/4"	16,3	80	46	32	24	5,6	0,280
1 2662 13	25	25	1"	19	90	55	41	25	8,2	0,540
1 2662 14	32	25	1 1/14"	14	93	62	47	32	16,5	0,363
1 2662 15	40	25	1 1/2"	16	105	69	54	36	27,4	0,804
1 2662 16	50	25	2"	18	125	83	67	46	36,7	1,310

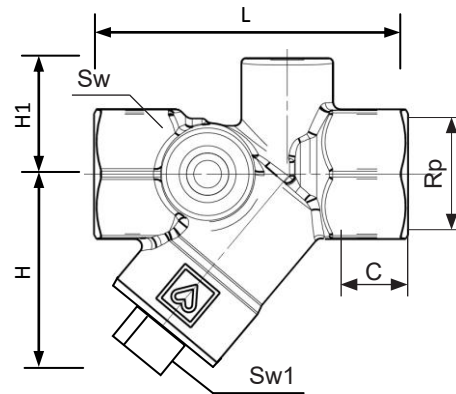

Order number	DN	PN [bar]	Rp [in]	C [mm]	L [mm]	H [mm]	Sw [mm]	Sw1 [mm]	Kvs [m ³ /h]
1 4111 14	32	25	1 1/4"	21,4	110	70	50	32	21,5
1 4111 15	40	25	1 1/2"	21,4	120	79	55	32	30,0
1 4111 16	50	25	2"	28,8	150	103	70	32	42,0
1 4111 17	65	16	2 1/2"	30	180	118	85	32	64,3
1 4111 18	80	16	3"	37	220	137	100	32	148,6

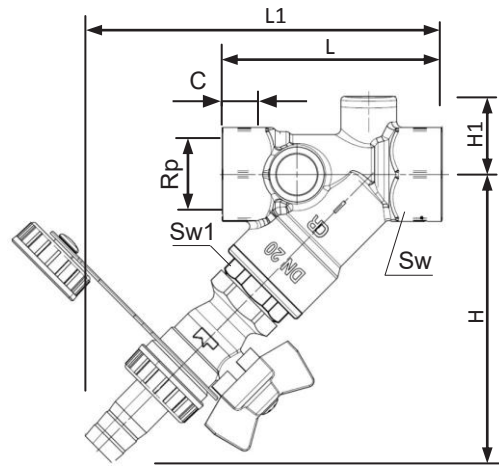
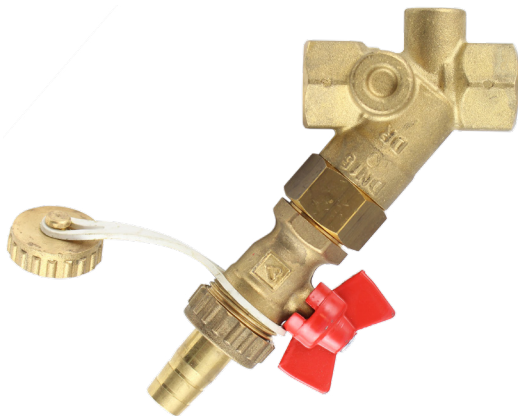

Order number	DN	PN [bar]	Rp [in]	C [mm]	L [mm]	L1 [mm]	H [mm]	H1 [mm]	Sw [mm]	Sw1 [mm]	Kvs [m³/h]
1 4111 41	15	10	1/2"	10,5	65	112	102	24	27	27	3,1
1 4111 42	20	10	3/4"	16,3	75	122	111	26	32	24	7,1

With external thread

Dimensions

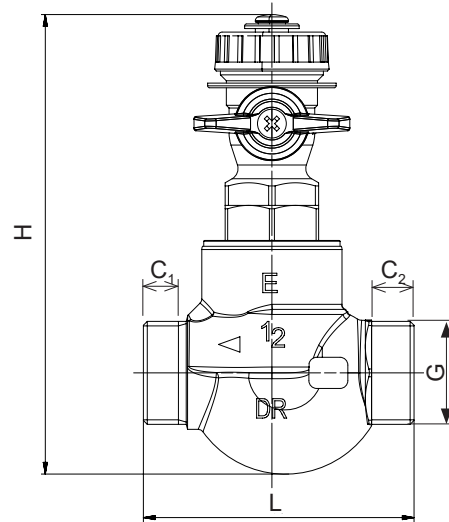

Order number	DN	PN [bar]	G [in]	C ₁ [mm]	C ₂ [mm]	L [mm]	H [mm]	Kvs [m³/h]	Sw [mm]
1 4111 21	15	25	3/4 flat sealing	10,9	11	69,5	118	3,6	24
1 4111 22	20	25	1 flat sealing	11	11	75	120	5,1	24
1 4111 23	25	25	1 1/4 flat sealing	15	11,6	90	118	5,0	24
1 4111 24	32	25	1 1/2 flat sealing	16	11,67	113	142	11,2	27

Material and construction

N	Description	Material
1 2662 1X		
1	Closing plug	forged brass acc. to EN 12420, CW602N
2	Plug seals	EPDM
3	Body	DN 15-40: forged brass acc. to EN 12420, CW602N; DN 50: casted brass acc. to EN 1982; CC770S
4	Sieve	stainless steel, single, meshed perforation 0,5mm
Internal threaded side connection Rp acc. to ISO 7/1		
1 4111 1X		
1	Closing plug	forged brass acc. to EN 12420, CW617N
2	Plug seals	EPDM
3	Body	casted, dezincification-resistant brass CC770S
4	Sieve	stainless steel, single, meshed perforation 0,75mm
Internal threaded side connection Rp acc. to ISO ISO 7/1		
1 4111 2X		
2	Plug seals	EPDM
3	Body	casted, dezincification-resistant brass CC770S
4	Sieve	stainless steel, single, meshed perforation 0,5mm
External threaded side connection G acc. to ISO 228-1		
Draining valve see data sheet 2512		
1 4111 4X		
2	Plug seals	EPDM
3	Body	casted, dezincification-resistant brass CC770S
4	Sieve	stainless steel, single, meshed perforation 0,5mm
Internal threaded side connection Rp acc. to ISO ISO 7/1		
Draining valve see data sheet 2512		

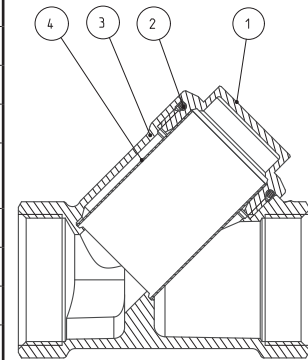
 Operating data
2662

Max. operating pressure	up to 25 bar
Min. temperature	- 30 °C (water 0,5 °C)
Max. temperature	130 °C (water 95 °C)

4111 XX

Max. operating pressure	depending on design, see table above
Max. temperature	110 °C

4111 2X

Max. operating pressure	up to 25 bar
Min. temperature	- 20 °C
Max. temperature	130 °C

Medium:

Heating water quality according to ÖNORM H5195 or VDI-Standard 2035. The use of ethylene or propylene glycol in a mixing ratio 25- 50% is allowed. Please refer to manufacturers documentation when using ethylene glycol products for frost and corrosion protection. HERZ ball valve for heating and chilled water is not suitable for usage of aggressive medium (such as: acids, alkalis, combustible and explosive gases) because it can destroy sealing components.

Application

Strainers are installed in pipes to protect the finely machined valve seats from particles. Field of application are building services, such as in heating or chilled water units for air conditioning in buildings. EPDM Sealings can be destroyed by organic hydro carbons, which are occurring in natural gas, mineral oil or lubricants.

Montage

A horizontal or vertical installation is possible, taking into account the flow direction. The screening mesh chamber should face down. HERZ recommends using standard thread sealants for the connection between strainer and pipe. The threads of the pipe are coated with a suitable sealing material (spinning material, Teflon ribbon, sealing paste) and the pipe end is screwed into strainer. When assembling use suitable assembly tool, that adapts to strainer end connections Sw. Special attention should be paid to the flow direction indicated on the housing with an arrow.

Maintenance instructions

Occasionally or after assembly and system leakage testing, the mesh sieve has to be cleaned by unscrewing the plug and replacing or cleaning the sieve. In order to prevent the medium outflow from the system when cleaning, it is recommended to build in a closing element (ball valve) before and after the strainer.

Brass

HERZ uses top-quality brass that responds to the latest European norms EN 12164 and EN 12165. Components of HERZ products are made from brass due to its good strenght, excellent corrosion resistance and variety of other properties.

Pursuant to Article 33 of the REACH Regulation (EC No. 1907/2006), we are obliged to point out that the material lead is listed on the SVHC list and that all brass components manufactured in our products exceed 0.1% (w / w) lead (CAS: 7439-92-1 / EINECS: 231-100-4). Since lead is a component part of an alloy, actual exposure is not possible and therefore no additional information on safe use is necessary.

Disposal instruction

The disposal of HERZ strainers must not endanger the health or the enviroment. National legal regulations for proper disposal of the HERZ strainers have to be followed.

Labels on strainer

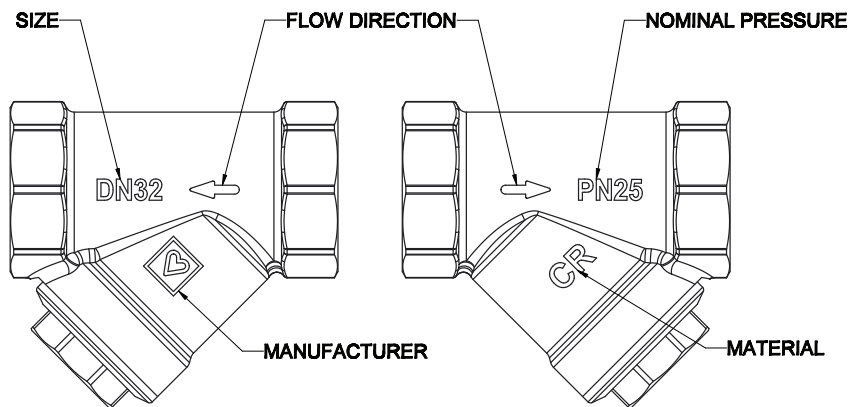

Spare parts

Illustration	Description	Item number	Suitable with
	Mesh 0,50mm	1 6386 11	1 2662 11
		1 6386 12	1 2662 12
		1 6386 13	1 2662 13
		1 6385 94	1 2662 14
		1 6385 95	1 2662 15
		1 6385 96	1 2662 16
		1 6386 31	1 4111 41
		1 6385 91	1 4111 42, 1 4111 21-23
		1 6386 29	1 4111 24
	Mesh 0,75mm	1 6386 14	1 4111 14
		1 6386 15	1 4111 15
		1 6386 16	1 4111 16
		1 6386 17	1 4111 17
		1 6386 18	1 4111 18

Flanged model

☑ Dimension

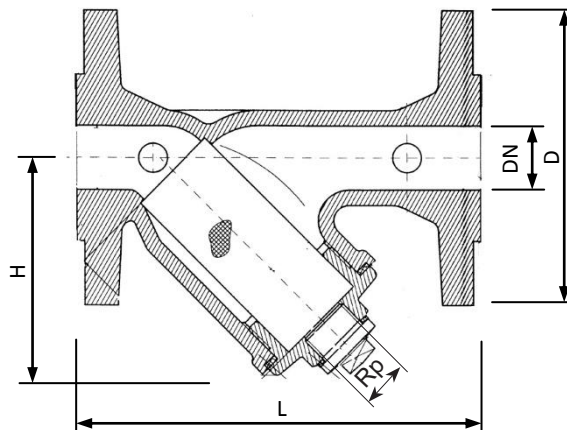

Order number	DN	PN [bar]	D [mm]	L [mm]	H [mm]	Kvs [m ³ /h]	Mass [kg]	Rp ["]
1 4111 83	25	16	115	160	85	12,8	4	1/2
1 4111 84	32	16	140	180	105	25,1	5,8	1/2
1 4111 85	40	16	150	200	140	34,3	7,6	3/4

☑ Materials

Body	grey cast iron EN GJL- 250, painted blue
Flange	EN1092-2, ISO 7005-2
Mesh	expanded metal, rhombic decoration, Stainless steel 1.4301, DN25 - DN50, Mesh size 0,75mm DN65 - DN80, Mesh size 1,25mm
Sealings	Graphite Cardboard, asbestos free

☑ Technical Data

Max. operating pressure	16 bar
Max. operating temperature	130°C
Heating water quality according ÖNORM H5195 or VDI-Standard 2035.	
The use of ethylene or propylene glycol in a mixing ratio 25- 50% is allowed.	

☑ Application

Strainers are installed in pipes to protect the finely machined valve seats from particles. Field of application are building services, such as in heating or chilled water units for air conditioning in buildings. EPDM Sealings can be destroyed by organic hydrocarbons, which are occurring in natural gas or mineral oil.

☑ Installation and maintenance

A horizontal or vertical installation is possible taking into account the flow direction. The screening space should face down. The strainer can be removed and cleaned by opening the locking screw. Drain the system before opening the locking screw. Reassemble in reverse order. Damage to the sealings have to be avoided. For service it is recommended to install isolators before and after the strainer.

☑ Spare Parts

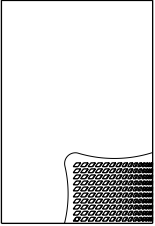
Illustration	Description	Item number	Suitable with
	Mesh 0,75mm	1 6386 23	1 4111 83
		1 6386 24	1 4111 84
		1 6386 25	1 4111 85
		1 6386 26	1 4111 86
	Mesh 1,25mm	1 6386 27	1 4111 87
		1 6386 28	1 4111 88

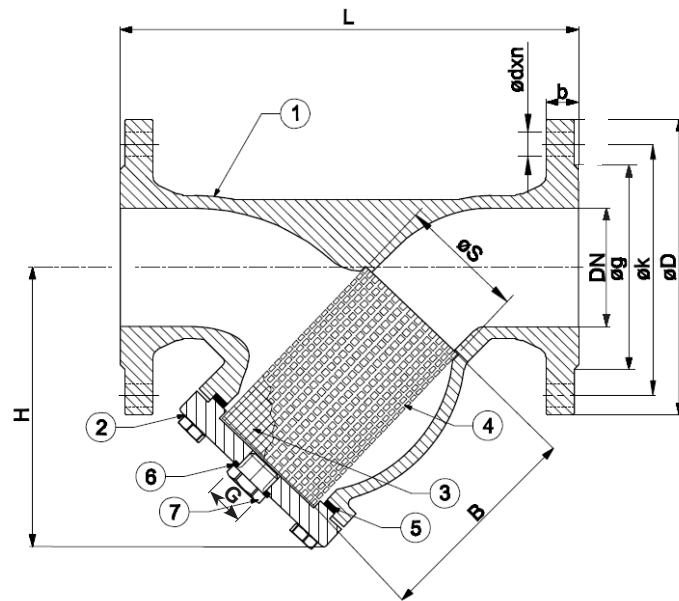
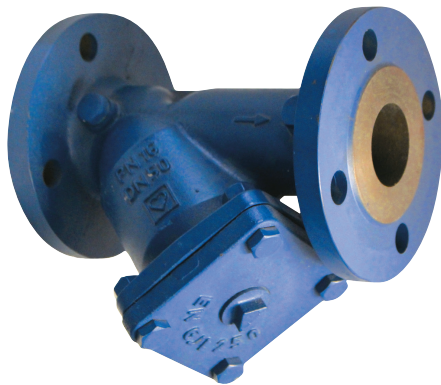
☑ Dimensions

Order number	DN [mm/"]	L [mm]	H [mm]	H _{max} [mm]	B [mm]	S [mm]	D [mm]	k [mm]	g [mm]	b [mm]	d [mm]	n [mm]	G ["]	Mass [kg]	Mesh [μm]
4 4111 80	50 2"	230	145	260	98	55	165	125	99	20	19	4	3/4	10,5	2000
4 4111 81	65 2-1/2"	290	165	333	132	78	185	145	118	20	19	4	3/4	16	2000
4 4111 82	80 3"	310	175	363	149	87	200	160	132	22	19	8	3/4	21,5	2000
4 4111 83	100 4"	350	236	454	192	109	220	180	156	24	19	8	3/4	28,5	2000
4 4111 84	125 5"	400	267	510	227	135	250	210	184	26	19	8	3/4	39	4000
4 4111 85	150 6"	480	298	579	244	160	285	240	211	26	23	8	3/4	52,5	4000
4 4111 86	200 8"	600	340	657	313	210	340	295	266	30	23	12	3/4	89,5	5000
4 4111 87	250 10"	730	390	875	394	258	405	355	319	32	28	12	1 1/4	149	5000
4 4111 88	300 12"	850	440	960	434	308	460	410	370	32	28	12	1 1/4	228	6000
4 4111 89	350 14"	980	520	1160	630	365	520	470	429	36	28	16	1 1/4	340	6000
4 4111 90	400 16"	1100	630	1329	645	410	580	525	480	38	31	16	1 1/4	505	6000
4 4111 92	500 20"	1250	900	1750	720	495	715	650	609	31.5	34	20	2	610	6000

☑ Specification

Temperature range: -10°C ... +120°C
 Pressure rate: PN16
 Flange Dimensions: according to EN1092-2

For hot and cold water systems for fluids excluding acid and flammable fluids. Heating water quality according ÖNORM H5195 or VDI-Standard 2035. The use of ethylene or propylene glycol in a mixing ratio 25- 50% is allowed.

Materials

Body (1)	DN 50 - DN300: grey cast iron EN - GJL-250, painted blue DN350 - DN500: spheroidal graphite iron EN - GJS-400-15, painted blue
Bonnet (2)	DN 50 - DN300: grey cast iron EN - GJL-250, painted blue DN350 - DN500: spheroidal graphite iron EN - GJS-400-15, painted blue
Filter (3)	Stainless steel AISI 304
Reinforcing frame (4)	Stainless steel
Gasket (5)	Klingerit
Plug gasket (6)	Copper
Plug (7)	St37

 kvs values

DN	Kvs
50	51
65	70
80	114
100	197
125	271
150	349
200	449
250	994
300	1396
350	2461
400	3645
500	5675

 Pressure loss calculation

The pressure loss in the valve can be calculated with below given formula.

$$1. \quad h_v = \frac{\zeta * w^2}{2g} \quad 2. \quad \Delta p = \zeta \frac{\rho * w^2}{2}$$

h_v	pressure loss (m)
Δp	pressure loss (Pa)
w	flow rate (m/s)
ζ	pressure loss coefficient
ρ	density (kg/m ³)
g	9,81 m/s ²

DN	50	...	400
ζ		~ 2,8	

 Spare Parts

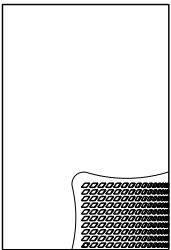
Illustration	Description	Item number	DN	Suitable with
	Mesh 2 mm	1 6387 60	50	4 4111 80
	Mesh 2 mm	1 6387 61	65	4 4111 81
	Mesh 2 mm	1 6387 62	80	4 4111 82
	Mesh 2 mm	1 6387 63	100	4 4111 83
	Mesh 4 mm	1 6387 64	125	4 4111 84
	Mesh 4 mm	1 6387 65	150	4 4111 85
	Mesh 5 mm	1 6387 66	200	4 4111 86
	Mesh 5 mm	1 6387 67	250	4 4111 87
	Mesh 6 mm	1 6387 68	300	4 4111 88
	Mesh 6 mm	1 6387 69	350	4 4111 89
Mesh 6 mm	1 6387 70	400	4 4111 90	

Please note: All specifications and information within this document are reflecting the information available at the time of going to print and meant for informational purpose only. Herz Armaturen reserves the right to modify and change products as well as its technical specifications and/or its function according to technological progress and requirements. All diagrams are indicative in nature and do not to be complete. It is understood that all images of Herz products are symbolic representations and therefore may visually differ from the actual product. Colours may differ due to printing technology used. In case of any further questions don't hesitate to contact your closest HERZ Branch-Office.

HERZ - Strainer	with female thread
Order No: 2662	DN 15 - DN50

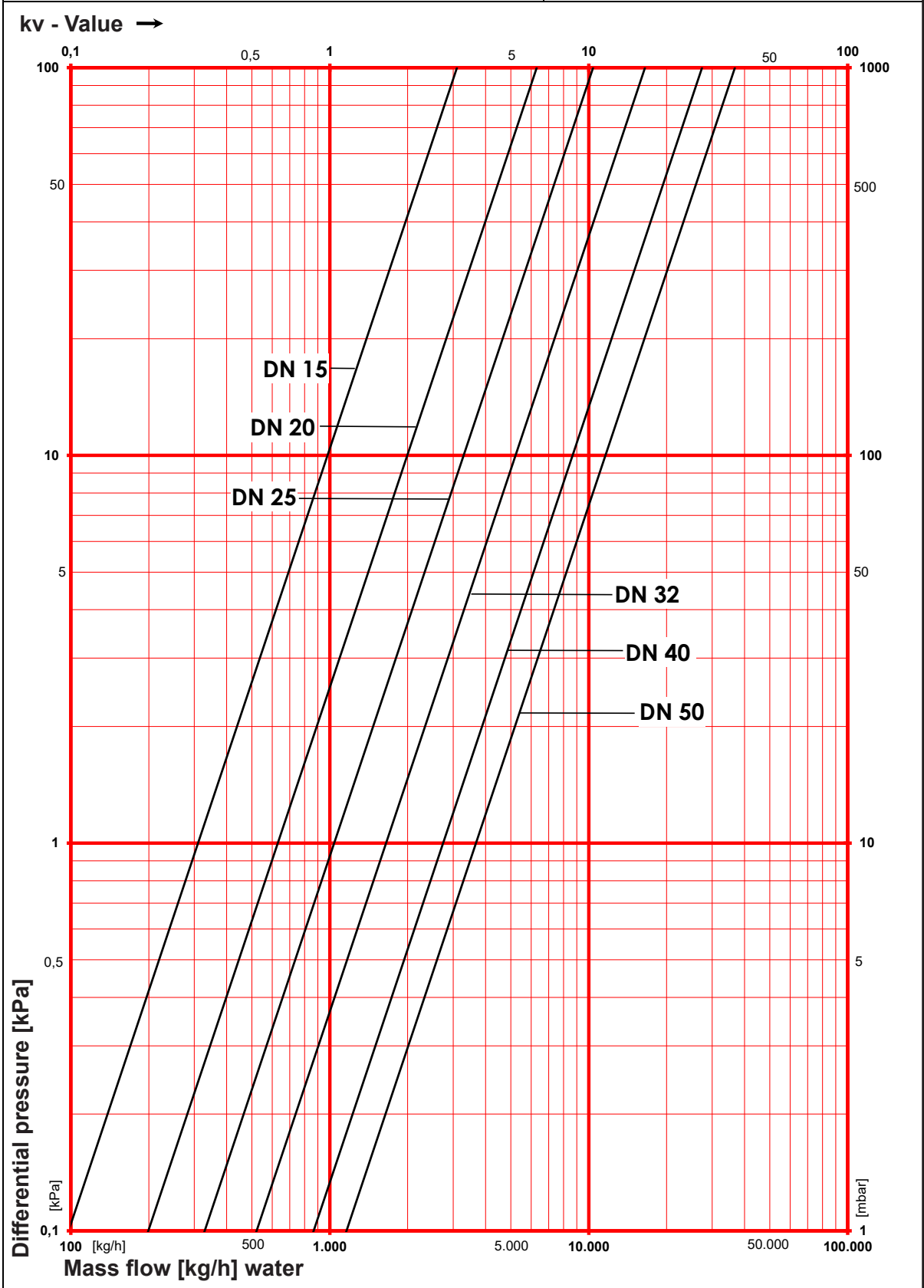

HERZ - Strainer	with female thread
Order No: 4111	DN 32 - DN80

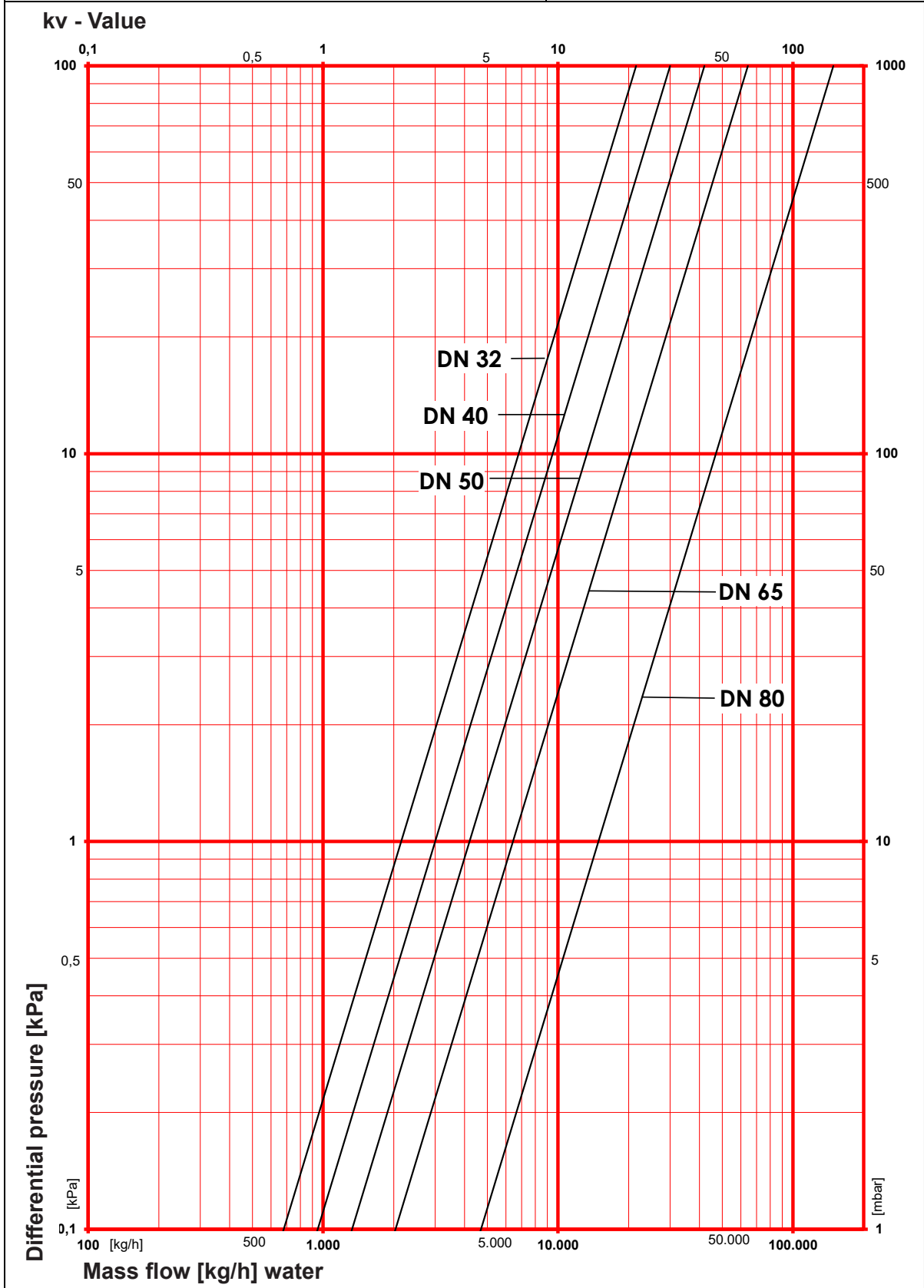

HERZ - Strainer	with male thread
Order No: 1 4111 2X	DN15 - DN32

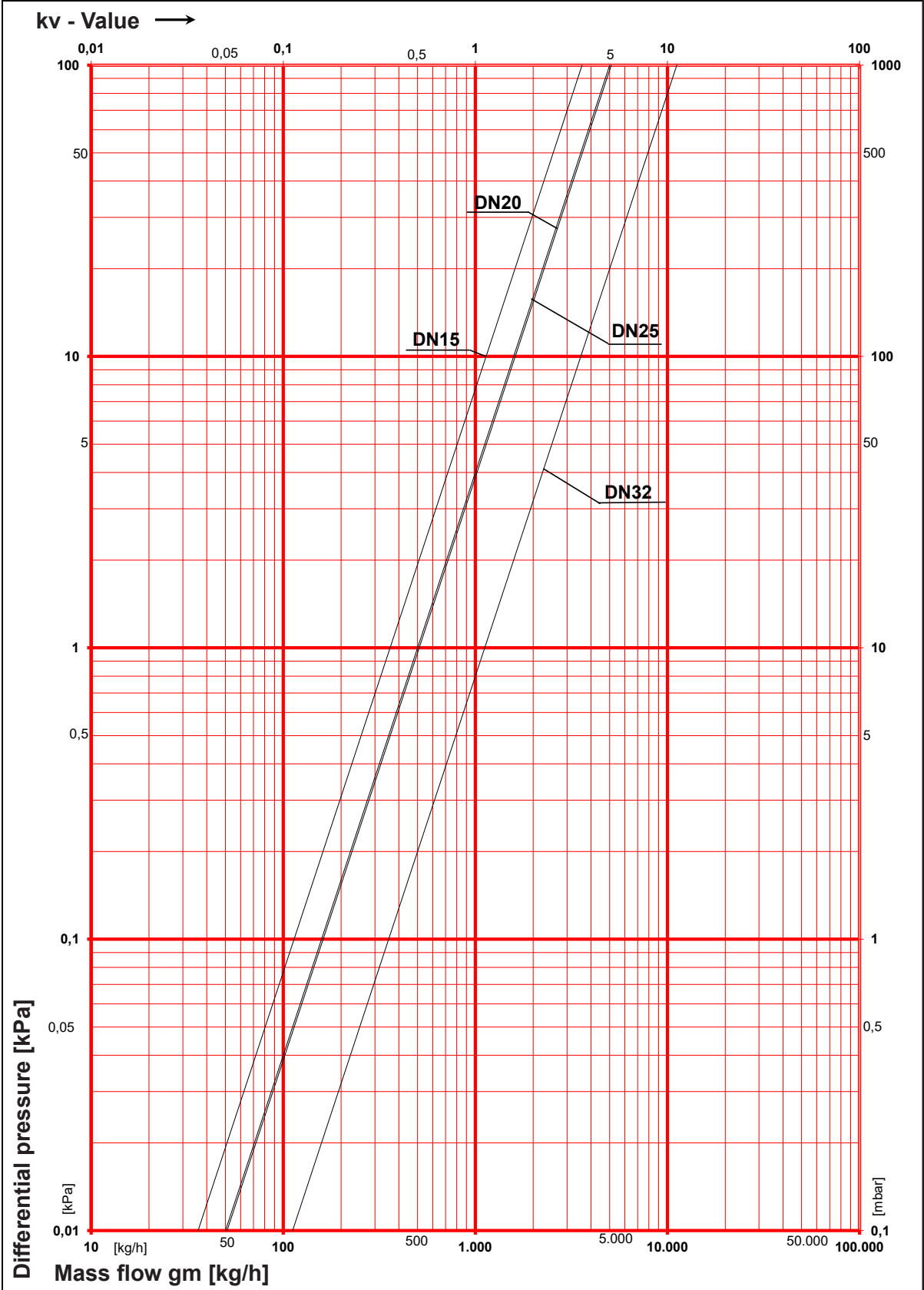

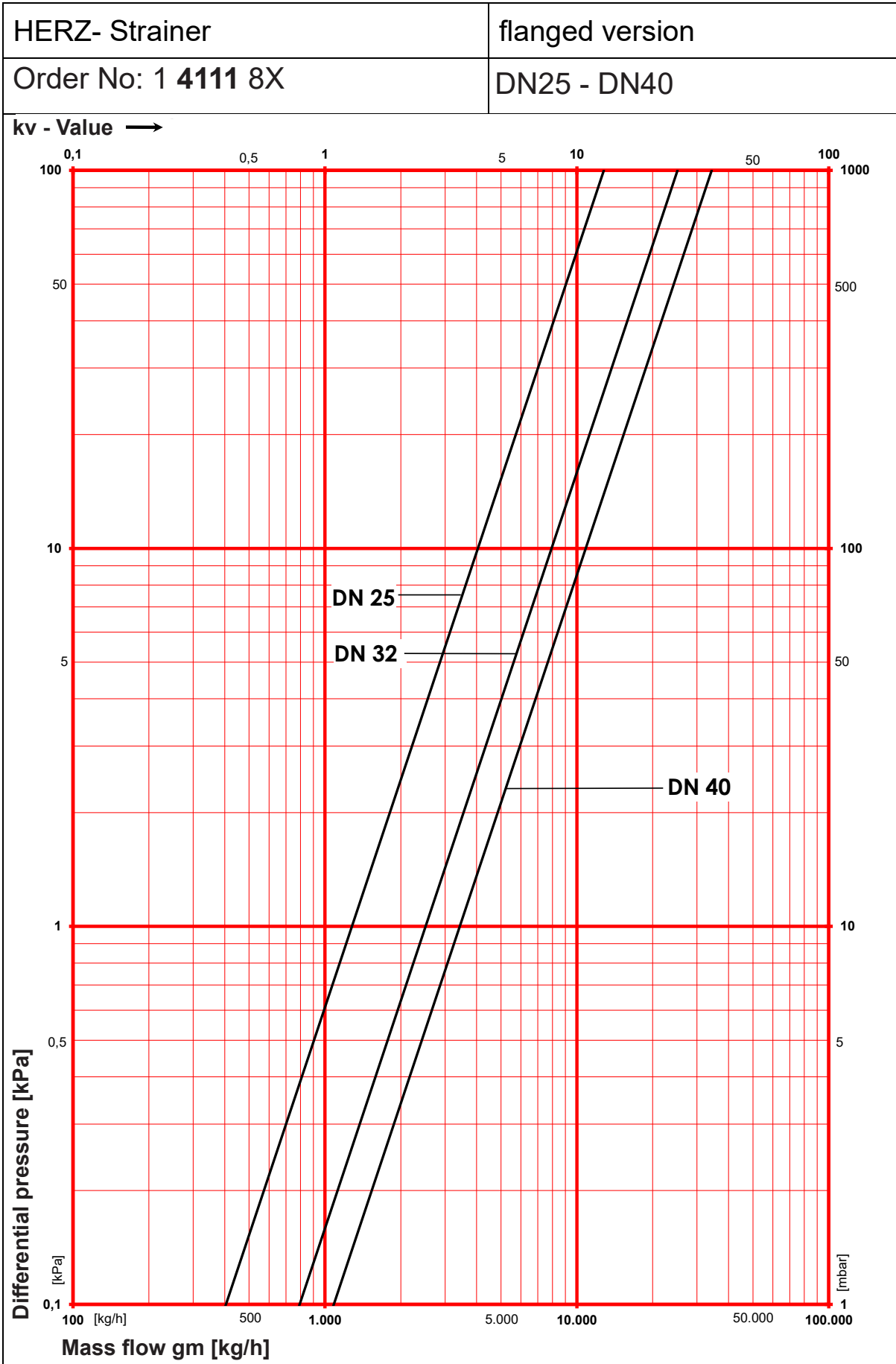

HERZ- Strainer

flanged version

Order No: 4 4111 8X

DN50 - DN500

