

Data sheet

Actuator for modulating control AME 435 QM

Description



AME 435 QM actuator for modulating control is used with pressure independent balancing and control valve type AB-QM from DN 40 to DN 100.

The actuator has some special features:

- it automatically adapts its stroke to the valve end positions which reduces commissioning time

- valve flow adjustment feature; flow can be variably-adjusted from linear to logarithmic or opposite.
- the advanced design incorporates load related 'switch-off' to ensure that actuators and valves are not exposed to overload

Main data:

- Nominal voltage (AC or DC):
 - 24 V, 50 Hz/60 Hz
- Control input signal:
 - 0(4)-20 mA
 - 0(2)-10 V
- Force: 400 N
- Stroke: 20 mm
- Speed (selectable):
 - 7.5 s/mm
 - 15 s/mm
- Max. medium temperature: 120 °C
- Self calibrating
- LED signalling
- External RESET button
- Output signal
- Manual operation

Ordering

Actuator

Type	Supply voltage	Code No.
AME 435 QM	24 VAC/DC	082H0171

Accessories-Adapter

Type	for valve's DN	for Actuator	Code No.
AB-QM adapter (2 st generation)	40-100	AME 15 QM	003Z0694
AB-QM adapter (1 st generation)		AME 435 QM	065Z0313

Technical data

Power supply	V	24 AC/DC; ±10%
Power consumption	running	VA 4,5
	standby	1,2
Frequency	Hz	50/60
Control input Y	V	0-10 (2-10); Ri = 95 kΩ
	mA	0-20 (4-20); Ri = 500 Ω
Output signal X	V	0-10 (2-10); RL = 650 Ω (maximal load)
Closing force	N	400
Max. stroke	mm	20
Speed	s/mm	7,5 or 15
Max. medium temperature	°C	120
Ambient temperature		0 ... 55
Storage and transport temperature		-40 ... 70
Protection class	II	
Grade of enclosure	IP 54	
Weight	kg	0,45
- marking in accordance with standards		Low Voltage Directive (LVD) 2006/95/EC: EN 60730-1, EN 60730-2-14 EMC Directive 2004/108/EC: EN 61000-6-2, EN 61000-6-3

Installation

Mechanical

No tool is required to mount actuator on the valve. Installation of the valve with the actuator is allowed in horizontal position or upwards. Installation downwards is not allowed.

The actuator must not be installed in an explosive atmosphere, at ambient temperature lower than 0 °C or at ambient temperature higher than 55 °C. It must not be subject to steam jets, water jets or dripping liquid as well.

Note:

The actuator may be rotated up to 360° with respect to the valve stem by loosening the retaining fixture. Once the actuator is placed, retighten the fixture.

Electrical

Electrical connections can be accessed by removing the actuator cover. Two cable gland entries without thread (Ø16 and combined Ø16/Ø20) are prepared for cable glands. From factory one entry is provided by rubber cable gland and the other entry is prepared for opening.

Note:

Cable and cable gland used must not compromise the actuator's IP rating, and must ensure the connectors are fully strain relieved. Rubber cable gland delivered from factory does not compromise IP rating but it does not provide fully strain relieve according to LVD directive. Please observe local rules and regulations as well.

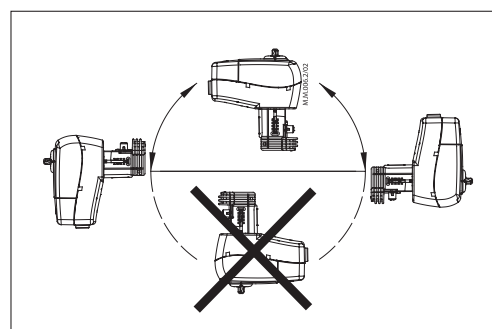
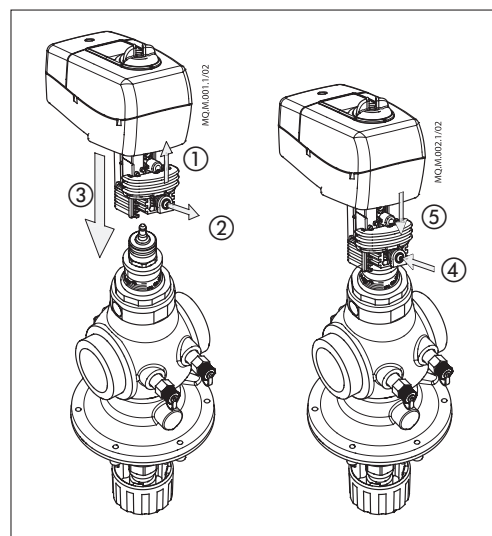

Commissioning

Complete the mechanical and electrical installation, set jumper and DIP-switches, then perform the necessary checks and tests:

- Apply power
Note that the actuator will now perform automatic Calibrating function
- Apply the appropriate control signal and check:
 - SW7 setting
 - the actuator drives the valve over the entire stroke length

The unit is now fully commissioned.

Automatic Calibrating feature

The actuator automatically adapts its stroke to the valve end positions :

- when power is applied for the first time or
- afterwards by pressing the STAND BY/RESET button for 5 seconds

Testing entire valve stroke length

The actuator can be driven to the fully-open or closed positions by connecting SN to terminals 1 or 3.

Disposal

The actuator must be dismantled and the elements sorted into various material groups before disposal.

Jumper/DIP switch setting

Jumper

- **U/I** - Input signal type selector
 - *U position*; voltage input is selected
 - *I position*; current input is selected

Factory setting: jumper is in U position.

DIP switches

Factory setting: all switches are in OFF position.

- **SW 1:** Not used
- **SW 2:** Input signal range selector
 - *OFF position*; the input signal is in the range from 0-10 V (voltage input) or from 0-20 mA (current input)
 - *ON position*; the input signal is in the range from 2-10 V (voltage input) or from 4-20 mA (current input)
- **SW 3:** Direct or Inverse acting selector
 - *OFF position*; the actuator is in direct acting mode (stem extracts as voltage increases)
 - *ON position*; the actuator is in inverse acting mode (stem retracts as voltage increases)

If used with AB-QM valves, SW 3 is recommended to be in OFF position (factory setting).

- **SW 4:** Fast/Slow - Speed selector
 - *OFF position*; the actuating speed is 7.5 s/mm
 - *ON position*; the actuating speed is 15 s/mm
- **SW 5:** Not used

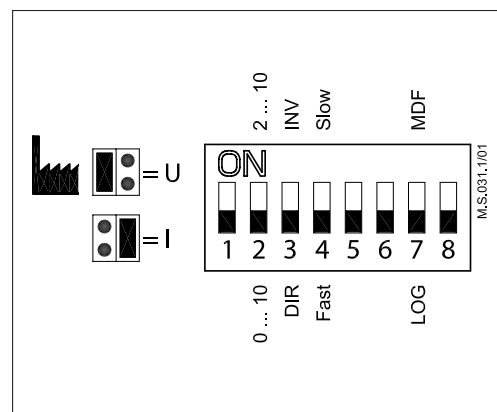

- **SW 6:** Not used
- **SW 7:** LOG/MDF - Logarithmic or modified flow through valve selector
 - *OFF position*; LOG ($\alpha=0.2$, factory setting)
 - *ON position*;MDF (initial setting: $\alpha=1$, linear)

Explanation:

If SW 7 is in OFF position, alpha knob is not activated. Turning alpha knob will not influence a value ($\alpha=0.2$).

If SW 7 is in ON position, a value can be manipulated using alpha knob. MDF initial setting of alpha knob is 1, which means linear setting. Regarding alpha knob setting see explanation below.

- **SW 8:** Not used

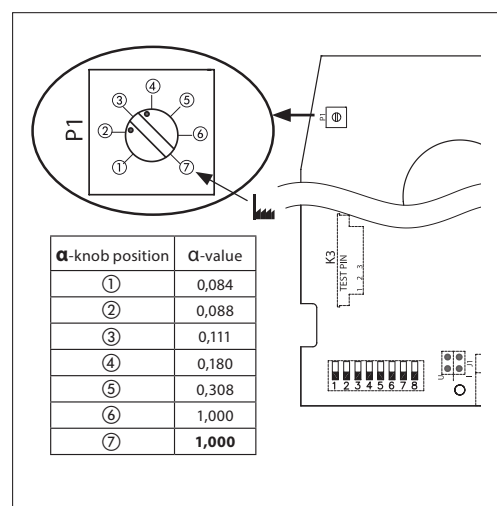
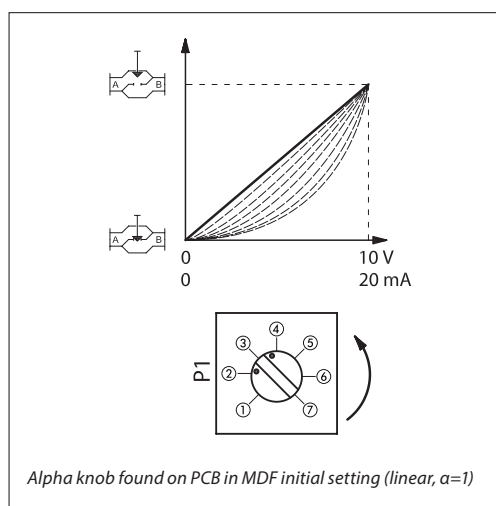

Equal-percentage valve-flow adjustment
(SW 7 in position ON)

The actuator has a special valve-flow adjustment feature called alpha value. Actuator characteristics can be, by turning the alpha knob counter clockwise (CCW), variably-adjusted from $\alpha=1$ (linear) to $\alpha=0.1$.

In order to have optimal control, linear characteristics of system (valve, actuator, HEX) is required. This can be assured using the right a value. Appropriate a value depends on temperatures of heating/cooling medium and controlled temperature of heated/cooled medium. Calculate a value according to the Tech Note number VNHUA102 (Setting the right a value).

**Led signalling/
Actuator operating modes**

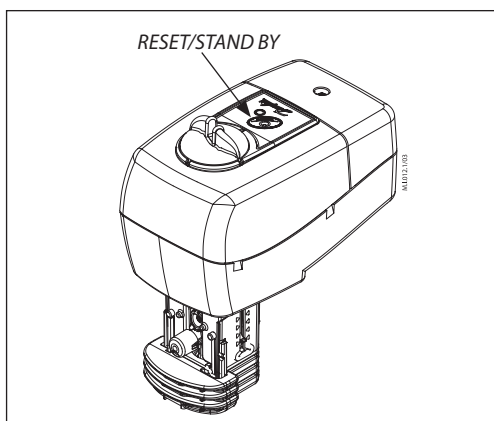

Flashing green LED: Calibrating mode (period is every second)	
Constant green LED: Positioning mode	
Flashing green LED: Normal mode (period is every 6 seconds)	
Flashing red LED: STAND BY mode (period is every two seconds)	

LED function indicator

The bi-colour (green/red) LED function indicator is located on the actuator cover. It indicates the operating modes.

External button

Actuator has external STAND BY/RESET button which is located next to LED indicator. By pressing on this button different operating modes are initiated:

- Calibrating mode**
Pressing the STAND BY/RESET button for 5 sec. causes the actuator to start *Calibrating procedure*:
The bi-colour LED flashes green at 1 sec. intervals during calibration procedure, which begins by extracting the stem. When the maximum force is detected (at the end valve position), the actuator then retracts the stem, until the maximum force is once again detected (on the other valve end position). The actuator will then enter to normal mode and respond to the control signal.

- Positioning mode**
The bi-colour LED is green and stays on during positioning of the actuator according to the control signal
- Normal mode**
When the positioning of the actuator is finished the LED flashes green every 6 seconds.
- STAND BY mode**
Pressing the STAND BY/RESET button switches the actuator to STAND BY mode. The actuator keeps its last position in this mode and does not react to any control signal. This mode can be used for manual operation during the commissioning of other equipment, or for service purposes.
The bi-colour LED flashes red at 2 sec. intervals.
After pressing the STAND BY/RESET button again actuator switches to normal mode.

Manual override

Manual override is done by means of control knob on actuator housing:

- Disconnect power supply or press STAND BY/ RESET button
- Adjust valve position using the control knob (observe the rotation direction)

When manual override is not needed:

- Restore power supply or press STAND BY/ RESET button again

Remark:

When the manual override has been used, the output signal (X) is not correct until the actuator reaches its end position.

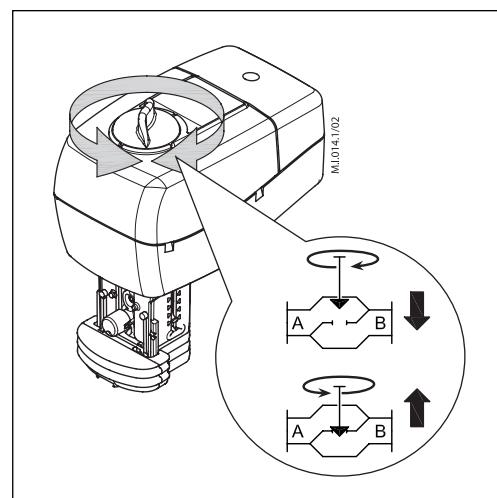

Wiring



24 VAC/DC only

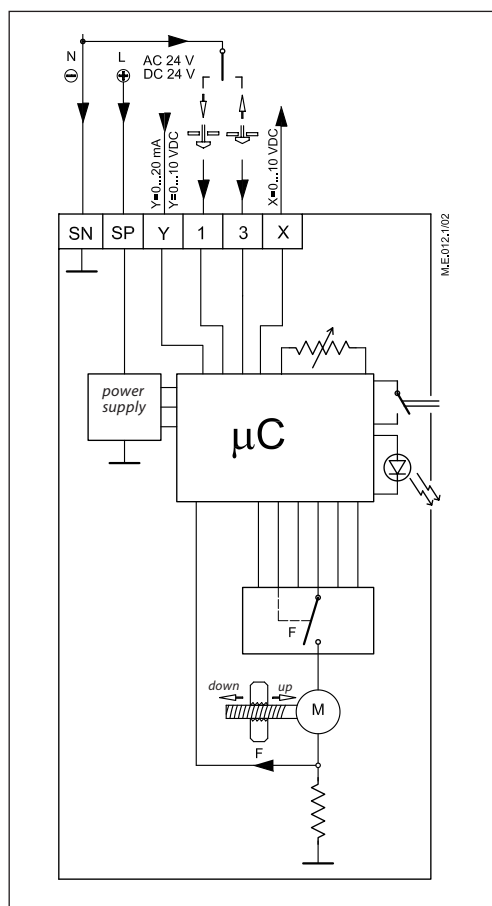

SP 24 VAC/DC Power supply

SN 0 V Common

Y 0-10 V Input signal
(2-10 V)
0-20 mA
(4-20 mA)

X 0-10 V Output signal
(2-10 V)

1, 3 Override input signal

The actuator can be driven to the fully-open position by connecting SN to terminal 1 or fully-closed by connecting SN to terminal 3. Signal 1 can be connected to thermostat to prevent freezing and signal 3 can be connected to thermostat to prevent overheating.

Wiring length	Recommended cross-sectional area of the wiring
0-50 m	0.75 mm ²
> 50 m	1.5 mm ²

Important: AME 435QM can be used only for modulating control. For 3-point control use AMV 435 (082H0162/163). It is recommend to use modulating control with AB-QM.

Actuator - valve combinations

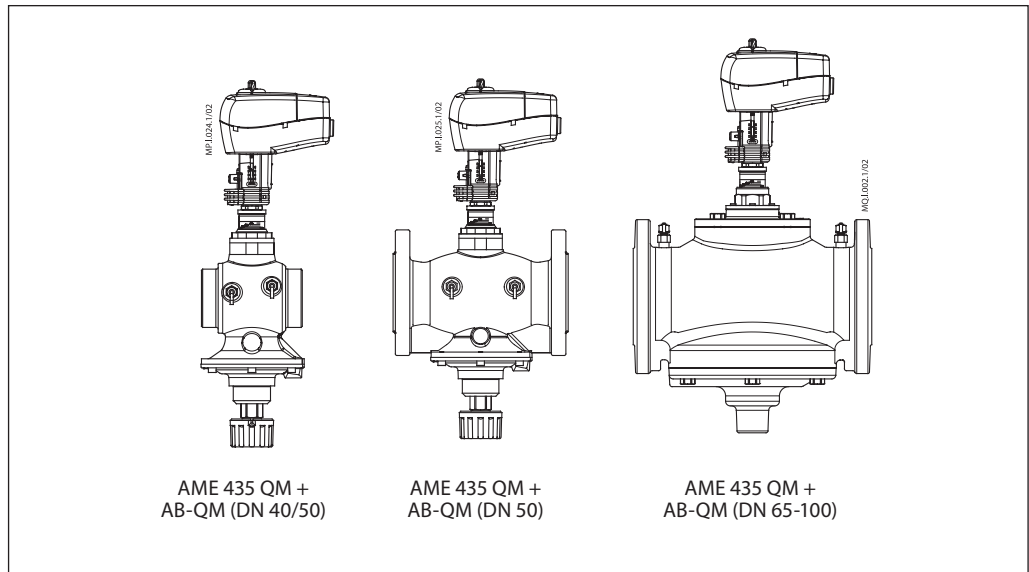

Dimensions

